

Modular MTD

The Next Generation of Chillers



The Cruisair MTD is a modular chiller engineered for optimal use of the new environmentally safe R-410A refrigerant. This tempered-water unit provides installation flexibility, reliability, maximum performance, and easy accessibility for maintenance and repair.

Flexible hose improves alignment for customer connections, and all seawater connections are reinforced with stainless-steel for added strength. Thermal expansion valves optimize performance over a wide range of conditions, while a hot-gas bypass valve maintains heating performance in cold seawater and helps prevent water freezing in the heat exchanger. With heating performance effective in cold seawater temperatures as low as 38°F (3.5°C), the need for separate fossil fuel or electric water heaters is eliminated in most applications.

The MTD is available in capacities of 24,000 to 120,000 BTU/hr (2 to 10 tons), and you can use multiple modules in any combination to achieve the total desired capacity. Custom frame and water-manifold installation for multiple units are also available. A reverse-cycle unit, the MTD provides reliable cooling and heating.

Each MTD unit has two sub-modules. This lets you rotate a sub-module to achieve more convenient water-connection locations or compressor access. The sub-modules can even be separated for remote mounting when space is limited. Sub-module changes can be handled in the field or special ordered from the factory.

The MTD has many built-in protection devices. A wire harness with polarized plug is included for easy electrical connections.

MTD units are available with several different compressors to suit a variety of power systems, including: 230V/60Hz/1Ph, 220V/50Hz/1Ph, 230V/60Hz/3Ph, 380V/50Hz/3Ph, and 460V/60Hz/3Ph.

Optional Variable Frequency Drives (VFDs) are available, which eliminate start-up power surge and run the unit at full-capacity 60Hz even with 50Hz input. The VFD requires a 3-phase tempering unit, but can operate on 1- or 3-phase input power.

Key Benefits

- Engineered for optimal use of R-410A refrigerant.
- Modular design for installation flexibility.
- Reverse-cycle heating and cooling.
- Scroll compressors standard.
- Larger drain fittings for faster condensate drainage.
- Stainless-steel reinforced seawater connections.
- Flexible hose improves connection alignment.
- Removable seawater manifolds allow cleaning of condenser tubing.
- Integrated loop-water strainer and flow switch.
- Oversized heat exchangers for loop temperatures of 40° F (4.4° C) in cooling and 120° F (49° C) in heating.
- Thermal expansion valves optimize performance over a wide range of conditions.
- Hot-gas bypass valve maintains heating performance in cold seawater and helps prevent water freezing in the heat exchanger.
- 24,000 to 120,000 BTU/hr (2-10 tons).

Technical Specifications for MTD Tempering Units

Model	Capacity BTU/hr (Kcal/hr) ⁽¹⁾	Volts/Hz/Ph ^{(2) (3)}	Full Load Amps Cool	Full Load Amps Heat	Locked Rotor Amps	Dimensions (in/cm) ⁽⁴⁾					Connections		Weight (lb/kg) ⁽⁴⁾
						Height	Width 1	Width 2	Length	X	SW	CW	
MTD24C	24,000 (6,048)	230/60/1	6.4	9.5	58.3	17.0/43	12.8/32	12.8/32	25.3/64	0/0	5/8" Hose	1" FPT	145/66 155/70 155/70 155/70
MTD24CK		220/50/1	7.5	11.0	67.0								
MTD24DC		230/60/3	5.5	7.3	58.0								
MTD24EC		460/60/3	2.7	3.6	28.0								
MTD30C	30,000 (7,560)	230/60/1	8.4	12.2	77.0	17.0/43	12.8/32	13.4/34	25.3/64	3.5/9	3/4" FPT	1" FPT	160/73 160/73 160/73 160/73
MTD30CK		220/50/1	9.5	13.2	82.0								
MTD30DC		230/60/3	6.4	8.3	71.0								
MTD30EC		460/60/3	3.3	4.2	38.0								
MTD36C	36,000 (9,072)	230/60/1	10.9	15.6	112.0	23.5/60	12.8/32	13.4/34	25.3/64	3.5/9	1" FPT	1" FPT	195/89 190/86 190/86 190/86
MTD36CK		220/50/1	11.6	16.9	97.0								
MTD36DC		230/60/3	7.3	9.4	88.0								
MTD36EC		460/60/3	4.0	5.2	44.0								
MTD48C	48,000 (12,096)	230/60/1	13.0	19.1	135.0	23.5/60	12.7/32	13.4/34	25.1/64	3.5/9	1" FPT	1" FPT	215/98 215/98 215/98 215/98 220/100
MTD48CK		220/50/1	14.4	20.7	136.0								
MTD48DC		230/60/3	9.1	12.2	98.0								
MTD48EC		460/60/3	4.7	6.2	46.0								
MTD48ECK	380/50/3	4.9	7.0	51.5									
MTD60C	60,000 (15,120)	230/60/1	17.0	24.7	158.0	23.5/60	12.7/32	13.4/34	25.1/64	3.5/9	1" FPT	1.25" FPT	230/105 220/100 220/100 225/102 220/100
MTD60CK		220/50/1	21.5	30.1	176.0								
MTD60DC		230/60/3	10.6	14.4	110.0								
MTD60EC		460/60/3	6.2	8.2	75.0								
MTD60ECK	380/50/3	6.8	9.1	74.0									
MTD72C	72,000 (18,144)	230/60/1	23.3	32.5	148.0	23.5/60	12.7/32	13.4/34	25.1/64	3.5/9	1" FPT	1.25" FPT	250/114 240/109 240/109 240/109
MTD72DC		230/60/3	14.2	18.2	149.0								
MTD72EC		460/60/3	6.9	9.1	75.0								
MTD72ECK		380/50/3	9.0	11.7	101.0								
MTD96DC	96,000 (24,192)	230/60/3	19.5	24.9	195.0	23.9/61	16.7/42	17.7/45	33.1/84	3.75/10	1.25" FPT	1.5" FPT	350/159
MTD96EC		460/60/3	9.8	12.4	95.0								
MTD96ECK		380/50/3	10.8	13.6	111.0								
MTD120DC	120,000 (30,239)	230/60/3	27.9	32.8	239.0	27.8/71	16.7/42	17.7/45	33.1/84	3.75/10	1.25" FPT	1.5" FPT	460/209 460/209 475/216
MTD120EC		460/60/3	12.7	16.4	125.0								
MTD120ECK		380/50/3	13.3	17.8	118.0								

Compressor Electrical Power Specs ⁽²⁾	
Nominal Rating	Acceptable Range
230/60/1	208-240/60/1
220/50/1	220-240/50/1
230/60/3	208-230/60/3 and 190-220/50/3
220/50/3	200-220/50/3
460/60/3	440-480/60/3 and 380-420/50/3
380/50/3	380-420/50/3

Notes:

- ⁽¹⁾ Cooling capacity at 100°F (38°C) condensing temperature and 35°F (2°C) evaporating temperature. Reverse cycle heating capacity at 130°F (54°C) condensing and 45°F (7°C) evaporating temperature.
- ⁽²⁾ For more information regarding compressor voltages, refer to Field Notice #192-B3 on Dometic Environmental's Customer News and Information website (www.DometicEnviro.com).
- ⁽³⁾ See the Compressor Electrical Power Specs table above.
- ⁽⁴⁾ All dimensions are ± 1/2" (13mm). All weights are ± 10%.

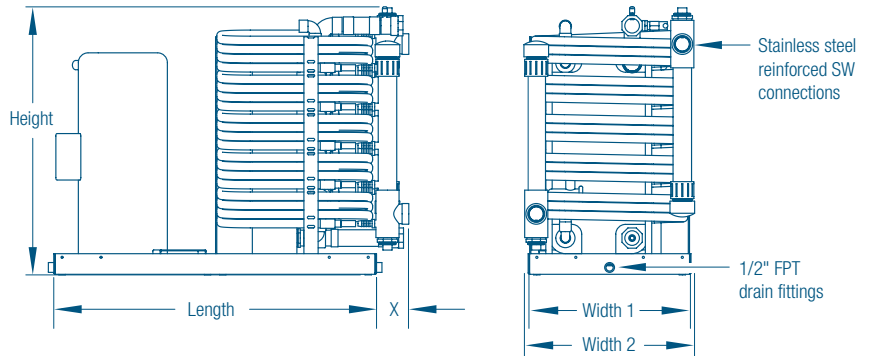

DOMETIC MARINE DIVISION

2000 N. Andrews Ave. Ext. I Pompano Beach, FL 33069 USA | 954-973-2477 | Fax 954-979-4414
www.DometicUSA.com | MarineSales@DometicUSA.com

24/7 Tech Support for United States & Canada:

8:00 AM to 5:00 PM Eastern Time: 800-542-2477
 After hours and weekends: 888-440-4494

International Sales & Service:

Europe & the Middle East: Call +44(0)870-330-6101
 For all other areas visit our website to find your nearest distributor.



Dealer: