

# Super Quiet AT-DC Air Handlers

## With WhisperCool Technology



AT18DC shown

**Dometic Marine creates the new standard in luxury yacht climate control that you'll barely notice - precisely what your clients are asking for - quiet nights.** WhisperCool Technology harnesses engineering refinements to eliminate annoying "motor hum" from traditional air conditioning blowers that occurs at very low speeds. Incoming alternating current is converted to drive a high-efficiency, brushless DC fan motor. The result is a much quieter fan operating across a broad range of variable speeds, permitting the user to select the desired comfort level.

Additional design changes in the air handlers eliminate condensate drain problems, reduce dripping condensation and standing water issues. An improved coil enhances cooling and dehumidification performance. The redesigned unit also creates easily accessible water-pressure test points for troubleshooting and maintenance.

Better dehumidification, better cooling, less noise... just the kind of performance one expects aboard a luxury yacht.

### Key Benefits

- Advanced super-quiet variable speed DC fan motor.
- Operates with Dometic Marine chilled water air conditioning systems.
- Engineering improvements eliminate condensate drain challenges – a positive-flow drain pan, larger drain connections, offset coil from drain-pan edge and a redesigned bypass valve.
- Improved coil design for better dehumidification and cooling.
- More-accessible maintenance points including water-pressure test ports.

# Technical Specifications for AT-DC Air Handlers

Model	AT6DC	AT9DC	AT12DC	AT18DC	AT24DC	AT36DC
Capacity (BTU/Hr)	6000	9000	12000	18000	24000	36000
Voltage (VAC)	208-230/ 50-60/1	208-230/ 50-60/1	208-230/ 50-60/1	208-230/ 50-60/1	208-230/ 50-60/1	208-230/ 50-60/1
Amps (FLA) Cool*	1.4	1.4	3.2	3.9	3.9	3.9
Optional Heater KW	1	1	1.5	1.5	3	3
Heater Amps	4.3	4.3	6.5	6.5	13.0	13.0
Amps (FLA) Heat*	5.7	5.7	9.7	10.4	16.9	16.9
<b>Max Fuse</b>						
Without Electric Heat	5	5	5	5	5	5
With Electric Heat	10	10	15	15	20	20
<b>Min Circuit Ampacity</b>						
Without Electric Heat	2	2	4	5	5	5
With Electric Heat	7	7	11	12	18	18
GPM/(liters/min)	1.5/5.7	2.25/8.5	3/11.4	4.5/17.0	6/22.7	9/34.1
CFM	200	300	400	600	700	800
External Static Pressure (in H2O)	2.9	2.8	2.6	2.1	1.4	0.5
<b>Dimensions (in/mm)</b>						
Height with blower (H1)	13.63/346	13.73/349	13.94/354	16.94/430	16.7/424	19.74/501
Height without blower (H2)	11.08/281	11.79/299	12.05/306	14.83/377	16.7/424	19.74/501
Width (W)	14.81/376	16.48/419	18.75/476	20.08/510	22.48/571	26.41/671
Depth (D)	14.27/362	14.55/370	14.49/368	14.83/377	16.42/417	17.15/436
Duct Ring Diameter (in/mm)	5/127.0	6/152.4	6/152.4	7/177.8	8/203.2	8/203.2
Minimum Supply Air Outlet (sq. in.)	35	49	70	100	140	196
Minimum Return Air Inlet (sq. in.)	70	98	130	200	240	360
Drain Connections	two 1/2" female NPT	two 1/2" female NPT	two 1/2" female NPT	two 1/2" female NPT	two 1/2" female NPT	two 1/2" female NPT
Chilled Water Connections, Female NPT	1/2"	1/2"	1/2"	1/2"	1/2"	1"
Net Weight (lbs/kg)	23/10.4	27/12.2	29/13.2	39/17.7	44/20.0	63/28.6
Gross Weight (lbs/kg)	33/15.0	37/16.8	39/17.7	49/22.2	58/26.3	72/32.7

\* Amps listed above are based on maximum speed in free air. Speed would be set well below maximum, and the unit would ordinarily be ducted rather than free air, therefore, the real world amps will be considerably lower.

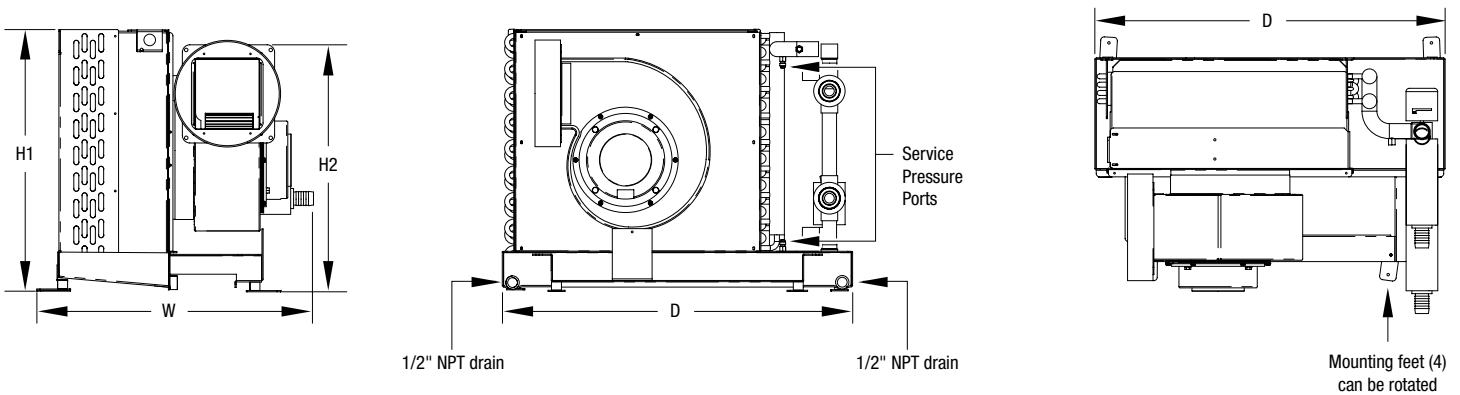

Dealer:

**DOMETIC MARINE**  
 2000 N. Andrews Ave. Ext. | Pompano Beach, FL 33069 USA | 954-973-2477 | Fax 954-979-4414  
 www.dometic.com

**United States & Canada Service Hours:**  
 8:00 AM to 5:00 PM Eastern Time

**24/7 AC SERVICE HOTLINE: 5:00PM to 8:00 AM: 888-440-4494**

**International Sales & Service:**  
 Europe & the Middle East: Call +44(0)870-330-6101  
 For all other areas visit our website to find your nearest distributor.

