



---

## AH-Elite Control (for CW systems)

---

### OPERATIONS MANUAL

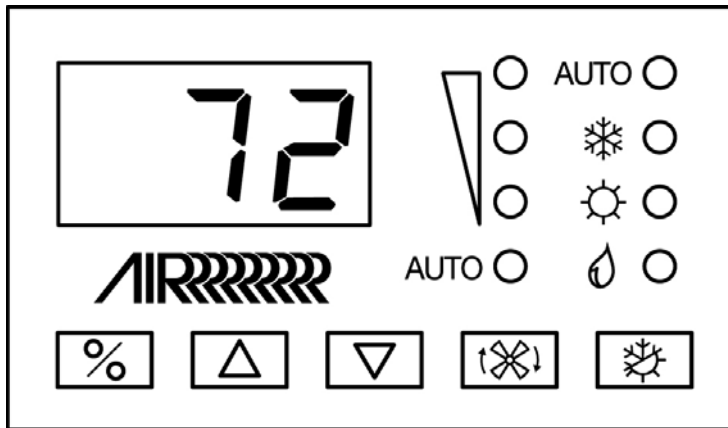

Dometic Marine  
Rev. 20091102  
L-2229 English



COPYRIGHT © 2007-2009 Dometic Marine. All Rights Reserved.

No part of this publication may be reproduced, translated, stored in a retrieval system, or transmitted in any form or by any means electronic, mechanical, photocopying, recording or otherwise without prior written consent by Dometic Marine. Every precaution has been taken in the preparation of this manual to ensure its accuracy. However, Dometic Marine assumes no responsibility for errors and omission. Neither is any liability assumed for damages resulting from the use of this product and information contained herein.

<b>INTRODUCTION</b> .....	<b>1</b>	Programmable Parameters .....	7
READ THIS MANUAL BEFORE PROCEEDING .....	1	FAULT-HANDLING CODES AND REMINDERS .....	11
FEATURES .....	1	TEMPERATURE DIFFERENTIAL OF AIR & WATER .....	11
Standard .....	1	<b>TROUBLESHOOTING</b> .....	<b>12</b>
Optional .....	1	GENERAL TROUBLESHOOTING .....	12
DESCRIPTION OF CONTROL .....	1	DIGITAL-CONTROLS TROUBLESHOOTING .....	13
Power .....	1	<b>MAINTENANCE</b> .....	<b>13</b>
Mode Selection .....	1	Return-Air Filter .....	13
Set Point .....	1	<b>SPECIFICATIONS</b> .....	<b>14</b>
Fan .....	1	OPERATIONAL .....	14
Memory .....	2	DIMENSIONS .....	14
IMPORTANT PROGRAMMING NOTES TO INSTALLER AND		CABLE LENGTHS .....	14
END USER .....	3	SYSTEM INPUTS .....	14
NORMAL HEATING OR COOLING CYCLE .....	3	<b>WARRANTY AGREEMENT</b> .....	<b>14</b>
<b>INSTALLING THE DISPLAY PANEL</b> .....	<b>3</b>	<b>DIAGRAMS</b> .....	<b>15</b>
CHOOSING THE LOCATION .....	3	SAMPLE APPLICATION .....	15
MOUNTING THE DISPLAY .....	3	SAMPLE WIRING DIAGRAM .....	16
MOUNTING THE OPTIONAL SENSORS .....	4		
Remote Air Sensor .....	4		
Outside Air Temperature Sensor .....	4		
Water Inlet Sensor .....	4		
<b>OPERATION</b> .....	<b>4</b>		
OPERATOR CONTROLS AND DISPLAY PANEL .....	4		
Display Indicators .....	4		
Button Functions - Single .....	5		
Button Functions - Dual .....	5		
MODES OF OPERATION .....	5		
Off Mode .....	5		
On Mode .....	5		
Automatic Mode .....	5		
Cool Mode .....	5		
Heat Mode .....	5		
Moisture Mode .....	5		
Fan Modes .....	6		
Program Mode .....	6		
USING PROGRAM MODE .....	6		
Entering Program Mode .....	6		
Exiting Program Mode .....	6		
Changing Parameters .....	7		
Memorizing New Program Parameters .....	7		
Restoring Memorized Default Settings .....	7		
Software Identification .....	7		
PROGRAMMING .....	7		
Programming procedure .....	7		

## INTRODUCTION

The AH-Elite Control is a microcontroller-based unit designed for use with direct expansion, reverse-cycle air conditioning systems.

### READ THIS MANUAL BEFORE PROCEEDING

Read this manual completely before you proceed with the installation and operation of the AH-Elite. If you have questions or require assistance with your AH-Elite control, contact the Dometic Marine Service Department at +1 954-973-2477.

The AH-Elite is covered under existing Marine Air Systems Warranty Policy. Incorrect installation, neglect and system abuse are not covered under Marine Air Systems warranty policy.

## FEATURES

### STANDARD

- User-friendly five-button display panel requires no manual for basic operation.
- Five-volt logic and microcontroller located in the display.
- Three-digit, seven-segment display panel indicates degrees Fahrenheit or degrees Celsius.
- Automatic and three programmable manual fan speeds.
- 18 programmable parameters for custom installations.
- High- and low-refrigerant-pressure sensor inputs.
- Moisture Mode for controlling relative humidity.
- Universal 115/230 volt, 50/60 Hz AC power supply.
- Nonvolatile memory retains settings without batteries.
- Programmable display-brightness control.
- Fits Vimar® switch bezels.

### OPTIONAL

- Outside air temperature sensor.
- Alternate air temperature sensor.
- Electric heating control capabilities.
- CAN-bus network capability (available in software revision A16 or newer).
- Air Filter Cleaning or Replacement Timer (available in software revision A15 or newer).

This manual provides all necessary information for proper installation and operation of the AH-Elite. Poor installation and misunderstood operating parameters will result in unsatisfactory performance and possible failure.

## DESCRIPTION OF CONTROL

See Figure 1 and Table 1 on page 2 to identify all parts of the control.

### POWER

Press the Power Button once to engage the system. The display is blank when the system is off and indicates current room temperature when the system is on.

### MODE SELECTION

Press and release the Mode Button until the desired Mode LED is illuminated.

### SET POINT

Press the Up or Down button to set the desired room temperature. To view the set point, momentarily press and release the Up or Down button.

### FAN

Fan-speed operation is automatic, allowing fan speed to decrease as set-point temperature is approached in the Cool Mode. The fan operates at low speed when set point is satisfied.

Normally the automatic fan speed operation is reversed in the Heating Mode, however, you can program the fan to operate the same as in the Cooling Mode.

Press the Fan button to select manual fan speeds if you want to override automatic operation. You can program the fan to run only during a cool or heat cycle, otherwise the fan runs constantly.

**MEMORY**

The AH-Elite has nonvolatile memory requiring no batteries or backup power. When power is lost, the operating parameters are retained indefinitely. When power is restored, the control resumes operating as last programmed.

**Figure 1: AH-Elite Display Panel and Indicators**

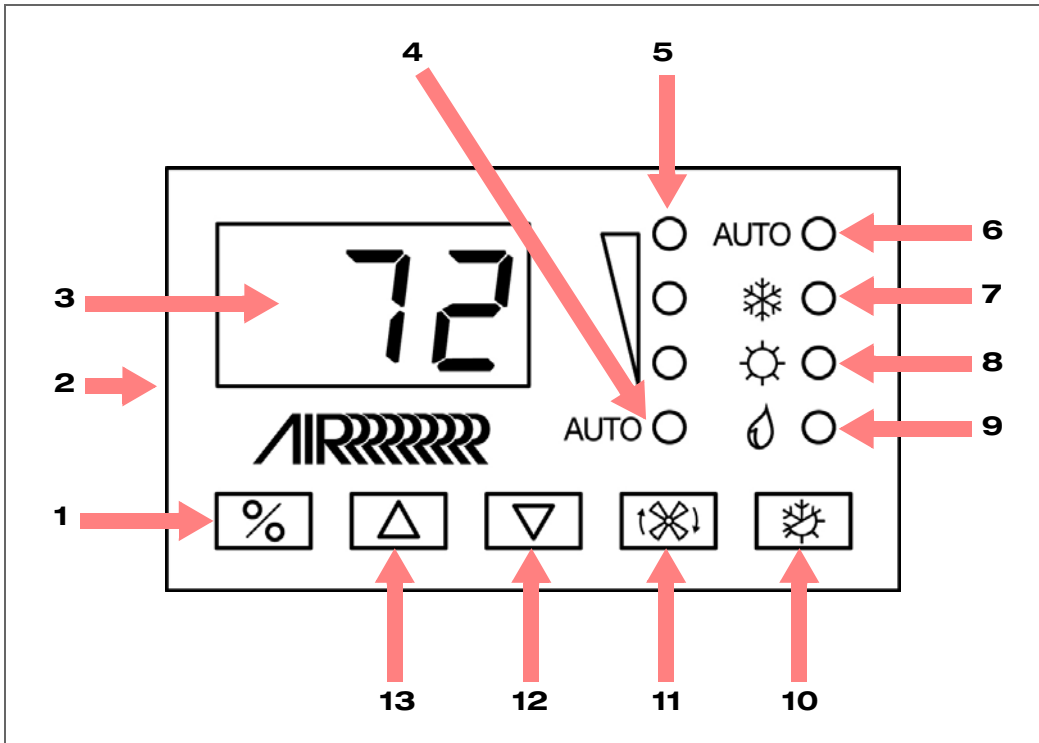

**Table 1: AH-Elite Display - Diagram Legend**

1	Power button	8	Heat Mode indicator
2	Temperature sensor	9	Moisture Mode indicator
3	Digital display	10	Mode button
4	Auto Fan indicator	11	Fan button
5	Manual Fan indicator (high, medium, low)	12	Down button - Lower temperature set point
6	Auto Mode indicator	13	Up button - Raise temperature set point
7	Cool Mode indicator		

## IMPORTANT PROGRAMMING NOTES TO INSTALLER AND END USER

1. If your air conditioning unit has a Shaded-Pole (SP) fan motor instead of a Split-Capacitor (SC) High-Velocity (HV) fan motor, you **MUST** program "SP" into parameter P-14 before operating the equipment. The SP units are recognizable by an overhanging blower motor. (The SC motor of an HV unit is inside the blower, and the unit has "VTD" or "HV" in the model number.) **Only reprogram this parameter if you do NOT have an HV blower.**
2. Standard air handlers come equipped with chilled-water bypass valves. However, for "no-valve" air handlers, the fan must be set to "Cycle On Demand". See "Cycled or Continuous Fan Operation" on page 6 under "Fan Modes" for instructions on how to change the fan operational mode to Cycled On Demand.

## NORMAL HEATING OR COOLING CYCLE

In **Automatic Mode**, heating and cooling are supplied as required. If cooling is required, the system will start a cooling cycle when the cabin temperature exceeds the set point by 2°F (1.1°C) and will continue to cool until the temperature equals the set point. (See "P-23: Set Point Temperature Differential" on page 9 for instructions on how to reduce this variation to 1°F [0.55°C].) The cabin temperature must drop below the set point by at least 4°F (2.2°C) in order for the system to switch from cooling to heating. Similarly, if heating is required, the system will start a heating cycle when the cabin temperature is below the set point by 2°F (1.1°C) and will continue to heat until the temperature equals the set point. The cabin temperature must exceed the set point by at least 4°F (2.2°C) in order for the system to switch from heating to cooling.

If you select **Cool Mode**, only cooling is supplied. If you select **Heat Mode**, only heating is supplied. The cabin temperature in either mode is maintained within 2°F (1.1°C) of set point by default. (See "P-23: Set Point Temperature Differential" on page 9 for instructions on how to reduce this variation to 1°F [0.55°C].) When the heating or cooling set point is satisfied, the hydronic water valve closes and the fan returns to low speed. The fan speed remains constant if Manual Fan Speed is selected.

For more information on this feature, see "Modes of Operation" on page 5.

**When cooling or heating is required**, the water valve will not open unless the water temperature is adequate. You can view the water temperature by simultaneously pressing the Power and Down buttons. The fan remains in low speed until the adequate water temperature is available. Heat will be supplied when no heating is available only if the Optional Electric heater has been installed and programmed.

**Adequate cooling or heating water temperature** is defined by programmable parameter P-16. Its factory default is set at 15°F (8.3°C) differential from the ambient air temperature.

## INSTALLING THE DISPLAY PANEL

### CHOOSING THE LOCATION

Before mounting the control panel, consider the location. The display panel's built-in air sensor provides excellent room-air temperature sensing when properly located and installed. For air sensor location see item 2 in Figure 1, page 2.

Mount the display panel on an inside wall, slightly higher than mid-height of the cabin, in a location with freely circulating air where it can best sense average temperature. Its distance from the air conditioner must be within the 15' (4.5m) length of the display cable (custom lengths available).

Do not mount the display in direct sunlight, near any heat-producing appliances or in a bulkhead where temperatures radiating from behind the panel may affect performance. **Do not mount the display in the supply-air stream.** Do not mount the display above or below a supply-air or return-air grille. Do not mount the display behind a door, in a corner, under a stairwell or any place where there is no freely circulating air.

If you can not mount the display in a suitable location for accurately sensing room temperature, install the optional remote air sensor.



#### IMPORTANT

The system's air sensor is located in the control's display panel, therefore the display **MUST** be located on an interior wall at eye level. It must **NOT** be located in direct sunlight or inside a cabinet.

If these conditions cannot be met, you must purchase the **Optional Remote Air Sensor** and install it in the return-air stream.

## MOUNTING THE DISPLAY

1. Make the cut-out for the display panel. Cut-out size is 3-5/16" (8.41cm) wide by 2-3/16" (5.56cm) high.
2. Plug one end of the display cable (8-pin connector) into the upper-right socket on the circuit board in the electric box and the other end into the back of the display panel.

3. Secure the display panel to the bulkhead using the four screws provided. Do not use a screw gun and do not over-tighten screws when mounting, because either method may damage the display.
4. When the display is securely mounted, mount the bezel over the display frame until it snaps into place.

## MOUNTING THE OPTIONAL SENSORS



### NOTE

Do not staple any sensor cables when mounting.

### REMOTE AIR SENSOR

Install the optional remote air sensor if the display can not be mounted in a proper location for accurately sensing room temperature. Installing the remote air sensor overrides the display's built-in sensor. The standard cable length for the remote air sensor is 7 feet (2.1m).

1. Mount the remote air sensor in the return-air stream behind the opening of the return-air grille.
2. Plug its cable (6-pin connector) into the "ALT AIR" socket #J4 in the upper-left corner of the circuit board.

### OUTSIDE AIR TEMPERATURE SENSOR

Install the optional outside air temperature sensor to monitor the temperature outside the cabin. Outside air sensor cables are available in various lengths.

1. Mount the sensor outside but not in direct sunlight.
2. Plug its cable into the "OAT" socket #J3.

### WATER INLET SENSOR

When using the AH-Elite with a chilled-water air handler, plug the water-inlet sensor cable into the "SERVICE/H2O" socket #J5. Attach the sensor to the chilled-water inlet on the air handler. Ensure that the sensor makes good contact with the copper pipe. DO NOT attach to rubber hose.

## OPERATION

### OPERATOR CONTROLS AND DISPLAY PANEL

Refer to Figure 1, page 2 for the button locations and display functions listed below.

#### DISPLAY INDICATORS

- **Auto Mode Indicator** - The Auto Mode LED lights when the system is in Automatic Mode, which switches to cooling or heating as required to satisfy the temperature set point.
- **Cool Mode Indicator** - The Cool Mode LED lights when the cool-only mode is selected or when the unit is in an Automatic Mode cooling cycle.
- **Heat Mode Indicator** - The Heat Mode LED lights when the heat-only mode is selected or when the unit is in an Automatic Mode heating cycle.
- **Moisture Mode Indicator** - The Moisture Mode LED lights when the Moisture Mode is selected. This mode controls humidity during periods when the vessel is unoccupied.
- **Manual Fan Indicator** - One of three Manual Fan Indicator LEDs lights when a manual fan speed (high, medium, or low) is selected.
- **Auto Fan Indicator** - The Auto Fan LED lights when the automatic fan speed is selected.
- **Water-Valve Status** - The system's water-valve operating status (whether the water valve is Open or Closed) displays by activating the Heat Mode or Cool Mode indicator when either mode is called for while in the Automatic Mode. No water-valve status is indicated when in manual Heat or Cool Modes. If the control is programmed for electric heat, then the indicator will light up if either the valve **or** the heater are energized.
- **Digital Display** - The 3-digit, 7-segment digital display shows inside air temperature when the control is on. It displays the set point when either the Up or Down button is pressed. The display also indicates program information and fault codes. When the control resumes operation after a power interruption, "888" appears in the display and all the LEDs light for one second. This is normal **Power-On Reset** operation.

## BUTTON FUNCTIONS - SINGLE

- **Power button** - Press and release to toggle between the On and Off Modes.
- **Up button** - Press and release to display the set point. Press and hold the Up button to increase the set point. Set point increases one degree each time the button is pressed.
- **Down button** - Press and release to display the set point. Press and hold the Down button to decrease the set point. Set point decreases one degree each time the button is pressed.
- **Fan button** - Press and release to advance from Auto Fan to Manual Fan. Press and release the Fan Button to advance the manual fan speeds, from low to high. Press and release again to return to the Automatic Fan mode. The selected Fan Mode is indicated by the Auto and Manual Fan LEDs. You can change the fan operating mode from continuous (“con”) to cycle-on-demand (“CYC”) by pressing and holding the fan button for 5 seconds.
- **Mode button** - Press and release to select one of the four operating modes. Continue to press and release the Mode Button until the desired operating mode is reached. The mode LEDs (Auto, Cool, Heat, or Moisture) light to indicate which mode is selected.

## BUTTON FUNCTIONS - DUAL

- **Up & Down buttons (On Mode)** - Simultaneously press the Up and Down buttons while in the On Mode to display outside air temperature (if the optional outside air temperature sensor is installed).
- **Up & Down buttons (Program Mode)** - Simultaneously press the Up and Down buttons while in the Program Mode to set new program defaults.
- **Power & Up buttons (On Mode)** - Simultaneously press the Power and Up buttons to view the chilled-water-inlet temperature.

## MODES OF OPERATION

### OFF MODE

When the control is in Off Mode, all control outputs are turned off. Program parameters and user settings are saved in nonvolatile memory. The Program Mode can only be accessed from the Off Mode.

### ON MODE

When the control is in On Mode, power is supplied to the appropriate outputs and the display indicates the current state of operation. The operating and program parameters resume based on those last stored when the unit was operating.

### AUTOMATIC MODE

When Automatic Mode is selected, the system provides both heating and cooling as required. The Auto Mode LED is lit as well as either the Heat Mode LED or Cool Mode LED, depending on which mode is in use. Cabin temperature in a given mode is maintained within 2°F (1.1°C) of set point by default. (See “P-23: Set Point Temperature Differential” on page 9 for instructions on how to reduce this variation to 1°F [0.55°C].) If the system was most recently cooling, the cabin temperature must drop below the set point by at least 4°F (2.2°C) in order for the system to switch from cooling to heating. Similarly, if the system was most recently heating, the cabin temperature must exceed the set point by at least 4°F (2.2°C) in order for the system to switch from heating to cooling. This behavior prevents small temperature overshoots from causing the system to switch between heating and cooling when it is not necessary.

### COOL MODE

When Cool Mode is selected, the Cool LED is lit and only the cooling system operates as required. If the ambient temperature drops below the set point, the system will not automatically switch to the Heat Mode.

### HEAT MODE

When Heat Mode is selected, the Heat LED is lit and only the heating system operates as required. If the ambient temperature rises above the set point, the system will not automatically switch to the Cool Mode.

### MOISTURE MODE

Use Moisture Mode to help control humidity while you are away from the boat or away from a particular cabin. While the control is in the On Mode, press the Mode button until the Moisture Mode LED is lit. Once Moisture Mode is enabled, the fan circulates the air for 30 minutes. During this time, the air temperature is sampled and entered into memory. After 30 minutes, a cooling cycle starts and continues until the temperature is lowered 2°F (1.1°C) or until the cooling cycle runs a maximum of one hour. Four hours after the temperature is satisfied or the cooling cycle times out, this cycle repeats.

**For software revision B23 and newer**, Moisture Mode will also prevent your boat or a particular cabin from dropping below a minimum temperature as a means to prevent the contents from freezing. When the temperature drops low, eliminating moisture

may become less of a concern and maintaining some minimum temperature may become more important. After the 30-minute fan circulation, if the temperature is at or above the factory default setting of 50°F (10°C), a cooling cycle is started and runs as described above. However, if the temperature is below 50°F (10°C), a heating cycle will be started instead. The heating cycle will continue until the temperature reaches 50°F (10°C) or until the heating cycle runs a maximum of one hour. Four hours after the temperature is satisfied or the cooling/heating cycle times out, the entire cycle repeats, each time determining whether cooling or heating is required. See “P-24: Moisture Mode Minimum Temperature” on page 9 for more information on how to adjust the 50°F (10°C) factory default to a different temperature that may better suit your particular requirements. The adjustment range is 40°F (4.4°C) to 75°F (23.9°C).

## FAN MODES

### Automatic Fan Mode

AH-Elite has three automatic fan speeds available: high, medium and low. Automatic Fan Mode allows the AH-Elite to determine the required fan speed based on temperature differential. This permits a balance between the most efficient temperature control and slower, quieter fan speeds. To select Automatic Fan Mode, press and release the Fan button until the LED next to the word “Auto” is lit.

### Manual Fan Mode

There are three manual fan speeds available: high, medium and low. Manual Fan Mode allows you to select and maintain a desired fan speed. When a manual fan speed has been selected, the speed is indicated by one of the 3 LEDs above the AUTO fan LED. The top LED represents the fastest speed. Press and release the Fan button until the LED next to the desired fan speed is lit.

### Fan-Only Mode

Use the Fan-Only Mode to operate the fan for air circulation when no cooling or heating is desired. From the Off Mode press and release the Fan button to start fan speed one. Press and release again to select speed two. Press and release a third time for speed three. Press and release a fourth time to turn off the fan. Turning on the control will revert the fan to the Automatic Mode or the last selected manual fan setting.

### Cycled or Continuous Fan Operation

The fan can be set to run continuously whenever the system is turned on, or it can be set to cycle on and off in conjunction with the cooling or heating cycles. To change this fan operational setting, press and hold the Fan button for five seconds. If the mnemonic “CYC” appears, the operational setting has been changed to cycled. If “con” appears, the operational setting has been changed to continuous.



### IMPORTANT

When used with optional electric heat, the fan remains on for four minutes after the heater cycles off even if fan is set to cycled operation.

## PROGRAM MODE

Use Program Mode to adjust operating parameters for your particular needs. Program Mode is also used to fine-tune the system for the most efficient operation within an installation. (Variables such as ducting, sensor location, and system layout affect system operation.) The control has factory default settings stored in permanent memory that can be recalled. However, reprogrammed settings can be saved as the new default, thus overwriting the factory defaults. See “P-15: Reset Memorized Defaults” on page 8 for details.

## USING PROGRAM MODE

### ENTERING PROGRAM MODE

You can only enter Program Mode from the Off Mode. If necessary, press the Power button to enter Off Mode. From the Off Mode and in the following order, press the Mode, Up, Down and Mode buttons. These buttons must be pressed and released in the order given. The characters “P 1” appear in the display, which represent the first programming parameter (High Fan Limit). The “P 1” is followed by the number “95” followed again by the parameter “P 1”. “95” represents the setting of the first programmable parameter (High Fan Limit). The AH-Elite control is now in the Program Mode.

### EXITING PROGRAM MODE

Press the Power button once to exit Program Mode and return to Off Mode. Or, do not attempt any programming for 50 seconds, then the control exits Program Mode and returns to Off Mode. Any programming changes made while in Program Mode will be saved and put into operation after exiting Program Mode and returning the control to the On Mode. (If you want the programming changes to become the new defaults, see “Memorizing New Program Parameters” on page 7.) When you exit Program Mode the software version number (such as “B23”) appears in the display.

## CHANGING PARAMETERS

While in Program Mode, press and release the Mode button to increment from one program parameter to the next until you reach the desired parameter number. Use the Fan button to move backwards through the parameters. The programmable parameters range from P-1 through P-24.

When you reach the desired parameter number, use the Up and Down buttons to select the data or set the desired limits for the parameter being programmed. See Table 2 on page 10 for a list of the parameters, the possible settings for each, and their factory default settings.

## MEMORIZING NEW PROGRAM PARAMETERS

If you want new parameters to be the program defaults, adjust the parameters to the desired settings, then press the Up and Down buttons simultaneously while in Program Mode. This memorizes the new settings as program defaults and exits the Programming Mode.

To return to the factory default settings, refer to the factory defaults listed in Table 2 on page 10 and reset the parameters manually.

## RESTORING MEMORIZED DEFAULT SETTINGS

You can restore the last memorized default settings by entering Program Mode and setting P-15 to “rSt”. The memorized default settings are restored and the control returns to Off Mode. See “P-15: Reset Memorized Defaults” on page 8 for details. To return to the factory default settings, refer to the factory defaults listed in Table 2 on page 10 and reset the parameters manually.

## SOFTWARE IDENTIFICATION

The control’s software version (such as “B23”) appears in the display for one second prior to exit from Program Mode, then the control returns to Off Mode.



### NOTE

If you have any reason to contact Dometic about the system or programming the control, you must have the software identification number and air conditioning unit serial number available. The serial number may be found on the dataplate label.

## PROGRAMMING

### PROGRAMMING PROCEDURE

1. Enter Program Mode. (See “Entering Program Mode” on page 6 for details.)
2. Press and release the Mode button to increment from one program parameter to the next. Press and release the Fan button to decrement from one program parameter to the previous.
3. Use the Up and Down buttons to change the parameter’s setting.
4. Press the Power button to exit Program Mode and return the control to Off Mode. Or, to memorize the changes as the new defaults, simultaneously press the Up and Down buttons (optional).

### PROGRAMMABLE PARAMETERS

The system’s default parameters may be changed by the installing dealer or end user. Once new values are entered and memorized, the factory defaults are overwritten and the new parameters become the default values. You can restore the original factory default parameters manually. A summary of the parameters, the permitted values, and original factory default settings of each are listed in Table 2, page 10.



### IMPORTANT

If you have any programming problems or confusion occurs, reset the Memorized Default Settings by entering Program Mode and setting P-15 to “rSt”.

### P-1: High Fan Limit

Values for the upper fan-speed limit range from 56 to 95. Set a higher number to increase the fan speed or a lower number to slow the fan speed.

**P-2: Low Fan Limit**

Values for the lower fan-speed limit range from 30 to 75. Set a higher number to increase the fan speed or a lower number to slow the fan speed.

**IMPORTANT**

Once the high and low fan speed limits are set, the unit automatically readjusts the remaining speed to produce three equally spaced fan speeds in both Automatic and Manual Fan Modes.

**P-3: (Reserved for future use.)****P-4: Temperature Calibration**

This feature calibrates the ambient sensor within a range of  $\pm 10^{\circ}\text{F}$ . Adjust this parameter to display the correct room-temperature reading. Note that setting increments are in  $^{\circ}\text{F}$  even when the control is set to display  $^{\circ}\text{C}$ .

**P-5: (Reserved for future use.)****P-6: (Reserved for future use.)****P-7: (Reserved for future use.)****P-8: (Reserved for future use.)****P-9: Display Brightness Control**

The display brightness can be adjusted from 4 to 18, with 4 being the dimmest and 18 the brightest. Typically a dark cabin will require a setting of 4 or 5. A very bright cabin will require a setting of 12 to 18.

**P-10: Fahrenheit or Celsius Selection**

The default setting is  $^{\circ}\text{F}$ . Select  $^{\circ}\text{C}$  for Celsius. (Celsius readings are displayed in tenths, for example  $22.2^{\circ}$ ).

**P-11: (Reserved for future use.)****P-12: Reverse Automatic Fan Speeds During Heating**

The automatic fan speeds can be reversed during Heat Mode to improve heat output in cooler climates. The fan will speed up as the set point is approached. Lowering the fan speed when the cabin is cold helps raise supply temperature. The fan switches to low speed when the set point is satisfied and the water valve cycles off. The fan can be programmed to operate the same as in cooling by programming P-12 "nor" which represents normal fan operation during reverse-cycle heating.

**P-13: Reverse-Cycle or Electric Heat**

Units may be equipped with an electric heater which is used to heat an individual cabin when the chiller system is in cooling mode. Set to "ELE" for the electric heat option or "nor" to disable.

- **For software revision A13 and older:** When this parameter is programmed for electric heat, only the electric-heat relay located toward the middle of the circuit board is energized during a heating cycle (see "Sample Wiring Diagram" on page 16).
- **For software revision A15 and newer:** When programmed for electric heat, both the electric-heater relay and the valve relay are energized. This change supports newer circuit board revisions without the electric-heater relay. Therefore, circuit boards that do not have electric-heater relays require a display with software revision A15 or newer to properly energize the compressor relay. Also, when using this configuration the electric heater L-1 connection must be connected to the COMP L-1 terminal on the AH-Passport I/O circuit board (see "Sample Wiring Diagram" on page 16). Please consult with Dometic Customer Service or with an authorized service technician for assistance.

**P-14: Fan Motor Selection**

The "SC" (Split Capacitor) default setting is correct for air handlers with high-velocity blowers. Only change the setting to "SP" if your unit has a Shaded Pole fan motor, recognizable by a blower-motor overhang. (The SC motor of a high-velocity unit is inside the blower, and the unit has "VTD" or "HV" in the model number.)

**P-15: Reset Memorized Defaults**

To reset all programming parameters set this parameter to "rSt". This restores all programmable parameters to the **last saved default values**. Once new values are entered and memorized the factory defaults are overwritten, and the new parameters become the default values. To restore the original factory default parameters manually, refer to Table 2, page 10.

**P-16: Hydronic Water Valve Forced Open**

This parameter opens the water valve to bleed air from the system. "OPn" forces the valve open for 4 hours while the AH-Elite control is turned off. If the control is turned on or if AC power is interrupted to the control's electric box during this 4-hour period, this valve override feature is canceled. You can return the valve to normal operation at any time by changing P-16 back to "nor" manually. (NOTE: This feature was modified to include the automatic, early cancellation in software revision A15.)

**P-17: Water Temperature Differential**

This parameter sets the temperature differential between ambient air temperature and hydronic water temperature that controls the water valve. For example, selecting 10°F opens the valve when water temperature is ten degrees less than ambient in cooling mode and 10°F greater than ambient in the heating mode.

Careful selection of the temperature differential can fully utilize the ship's heating and cooling resources. For example, while in cooling mode and using a ten degree value, the valve will open to allow some cooling while the hydronic system is coming down to temperature. See Figure 2 on page 11 for a graphical explanation of this parameter.

**P-18: Air Filter Cleaning/Replacement Timer Setting**

**(Available only in software revision A15 and newer.)** Use this feature for a reminder to clean or replace the unit's air filter. The parameter entered represents that number times 10 hours. Select the number of operating hours until the filter reminder appears. Parameter choices are between 10 (100 hours) and 250 (2500 hours). Dometic recommends that you check the air filter at least every 500 hours of operation. The default setting is off, designated with "00".

Once set, the timer keeps track of the total amount of run hours that the fan accumulates (see P-19). Once the timer setting is reached, "FIL" flashes briefly on the LED display every 10 seconds until it is cleared. Display of the room temperature continues and the normal operation of the system is not affected. The "FIL" reminder can only be cleared and the timer reset via programmable parameter P-19. See below for instructions.

**P-19: Filter Cleaning/Replacement Timer Value & Reset**

**(Available only in software revision A15 and newer.)** This parameter displays the current elapsed time (in hours times 10) since the timer was started or reset. For example, if the value of P-19 is "30", then between 300-399 hours have elapsed since the timer was started or reset. Once the value of P-19 reaches the value set in P-18 (explained above), "FIL" flashes on the LED display every 10 seconds until it is cleared. To clear the "FIL" reminder, press either the Up or Down button while viewing the P-19 parameter. This resets P-19 to 0 and restarts the timer.

**P-20: CAN-bus Unit ID**

**(Available only in software revision A16 and newer.)** This parameter displays only when CAN-bus network capability is available and the AH-Elite is plugged into a networked Passport I/O power and logic board. This parameter does not display when the AH-Elite is plugged into a standard board. Each control on the same CAN-bus network must be assigned a unique Unit ID (0 - 255). For example, the control that has P-20 set to 5 will respond to commands with a destination address of 5.

**P-21: CAN-bus Group ID**

**(Available only in software revision A16 and newer.)** This parameter displays only when CAN-bus network capability is available and the AH-Elite is plugged into a networked Passport I/O power and logic board. This parameter does not display when the AH-Elite is plugged into a standard board. Assign the address for the control's CAN-bus network group (0 - 255). This number should be unique and different than any CAN-bus Unit ID. For example, all controls that have P-21 set to 100 will respond to commands with a destination address of 100 (in addition to responding to commands that target their individual Unit IDs).

**P-22: Voltage Calibration**

**(Available only in software revision A15 and newer.)** This feature displays the voltage being read by the power and logic circuit board. It displays a live reading of the voltage and can be manipulated by pressing the Up or Down buttons. Use a reliable voltmeter as a reference when adjusting this parameter.

**P-23: Set Point Temperature Differential**

**(Available only in software revision B23 and newer.)** This parameter is the temperature differential in Fahrenheit for all modes of operation: Automatic, Cool, or Heat. Refer to "Modes of Operation" on page 5 for more information on how this parameter affects these modes. By default, this parameter setting is 2°F (1.1°C). It can be set to either 1°F (0.55°C) or 2°F (1.1°C). Setting this parameter to 1°F (0.55°C) will result in the control maintaining the room temperature closer to the desired set point. However, this may result in more frequent shorter-duration cooling or heating cycles. In most cases, the factory default of 2°F (1.1°C) is adequate for maintaining a comfortable temperature variation around the desired set point. If you desire less variation in temperature, set this parameter to 1°F (0.55°C).

**P-24: Moisture Mode Minimum Temperature**

**(Available only in software revision B23 and newer.)** This parameter is the minimum room temperature in Fahrenheit for which Moisture Mode will run a cooling cycle to remove moisture from the air. If the room temperature is below this parameter setting, Moisture Mode will run a heating cycle instead. By default, this parameter is 50°F (10°C), and it can be adjusted between 40°F (4.4°C) to 75°F (23.9°C). Please refer to the description of "Moisture Mode" on page 5 for more information on how Moisture Mode functions and utilizes this parameter.

**Table 2: Programmable Parameters - Ranges and Factory Defaults**

Parameter Number	Description	Factory Default	Custom Default	Parameter Range
P-1	High Fan-Speed Limit	95		56 - 95
P-2	Low Fan-Speed Limit	50		30 - 75
P-3	Reserved for future options			
P-4	Temperature-Sensor Calibration	Ambient temp		Ambient plus or minus 10° F
P-5	Reserved for future options			
P-6	Reserved for future options			
P-7	Reserved for future options			
P-8	Reserved for future options			
P-9	Display Brightness Control	15		4 (Dimmest) - 18 (Brightest)
P-10	Display Temperatures in Fahrenheit or Celsius	F		F = Fahrenheit Displayed C = Celsius Displayed
P-11	Reserved for future options			
P-12	Reverse Fan Speeds During Heat Mode	rEF		nor = Normal Fan Operation rEF = Reversed Fan in Heat Mode
P-13	Reverse-Cycle Heating or Electric-Heat-Only Option Installed	nor		nor = Reverse-Cycle Heating ELE = Electric Heater Installed
P-14	Fan-Motor Type: Split Capacitor or Shaded Pole	SC		SC = Split Capacitor Fan Motor SP = Shaded Pole Fan Motor
P-15	Reset Memorized Programming Defaults	nor		rST = Reset Defaults nor = Normal
P-16	Hydronic Water Valve Forced Open	nor		OPn = Valve Forced Open nor = Normal Operation
P-17	Temperature Differential	15° F		5° F to 25° F
P-18	Air Filter Cleaning/Replacement Timer Setting (x10 hours) <sup>1</sup>	0		0 = Timer Disabled 10 - 250 (100 - 2500 hours)
P-19	Air Filter Cleaning/Replacement Value (x10 hours) & Reset <sup>1</sup>	0		Displays the elapsed time (in hours x10) since the timer was started or reset. Press Down button to reset value to 0, restart the timer, and clear the display's "FIL" reminder.
P-20	CAN-bus Unit ID <sup>3</sup>	0		0 - 255 (Each control on a CAN-bus network must have a unique Unit ID.)
P-21	CAN-bus Group ID <sup>3</sup>	0		0 - 255 (Address for the control's CAN-bus network group. Should be different than any CAN-bus Unit ID.)
P-22	Voltage Calibration	AC Voltage		Adjust to match the accurate voltage reading.
P-23	Set Point Temperature Differential <sup>4</sup>	2		1 = 1°F (0.55°C) Differential 2 = 2°F (1.1°C) Differential
P-24	Moisture Mode Minimum Temperature <sup>4</sup>	50°F		40-75°F (4.4-23.9°C)

<sup>1</sup>This feature is only available in software revision A15 and newer.

<sup>3</sup>This feature is only available in software revision A16 and newer.

<sup>4</sup>This feature is only available in software revision B23 and newer.

## FAULT-HANDLING CODES AND REMINDERS

One of the following fault codes displays when a fault is detected:

- **ASF** – Indicates air sensor failure.
- **FIL** – Indicates filter needs to be cleaned or replaced.

## TEMPERATURE DIFFERENTIAL OF AIR & WATER

The optional electric heater overlaps with the chilled-water heat by 22° F (12.2° C). The heater turns on when heat is required and remains on until the chilled-water temperature exceeds the ambient by 22° F (12.2°C) or until the room temperature is satisfied. During very cold conditions electric heat overlaps the chilled-water heat to supplement heating. Note that parameter P-19 setting increments are in °F even when the control is set to display °C.

**Figure 2: Ambient Air to Water Temperature Differential**

Note: Chart uses the Default Value for P-17.

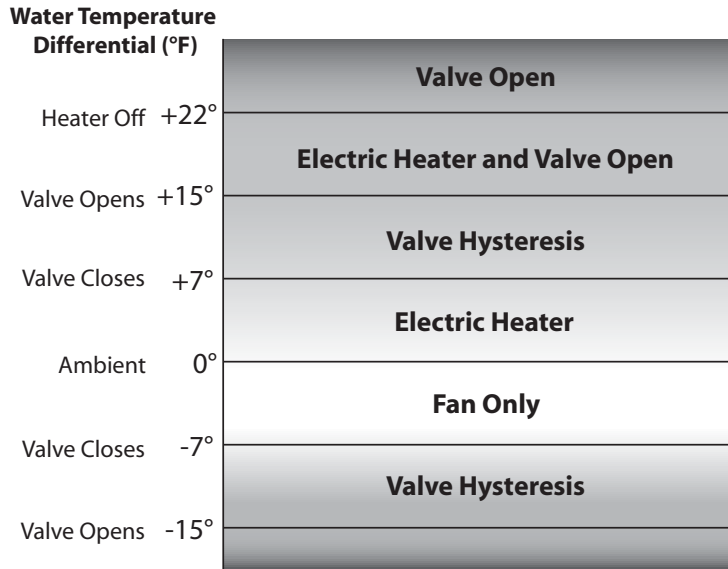

**Ambient Air to Water Temperature Differential**

# TROUBLESHOOTING

## GENERAL TROUBLESHOOTING

See also "Digital-Controls Troubleshooting" on page 13.

**Table 3: General Troubleshooting**

PROBLEM	POSSIBLE REASON/SOLUTION
System will not start.	<ol style="list-style-type: none"> <li><b>Air handler circuit breaker is off.</b> Turn circuit breaker on at ship's panel.</li> <li><b>Digital control is not turned on.</b> Turn on the control.</li> <li><b>Wrong wiring at terminal strip.</b> Check wiring diagram; correct if necessary.</li> <li><b>Input-line voltage is insufficient.</b> Check power source (shore/generator) for proper voltage. Check wiring and terminals for proper sizes and connections. Verify with a volt-meter that the power at the unit is the same as the power source.</li> <li><b>Push-on connectors or butt splices became disconnected during installation.</b> Disconnect power supply and open electric box, check wiring diagram, correct if necessary.</li> </ol>
Fan is not running.	Check "Digital-Controls Troubleshooting" on page 13.
No cooling or heating.	<ol style="list-style-type: none"> <li><b>Temperature set point is satisfied.</b> Lower or raise set point.</li> <li><b>Fan is not running.</b> Check your specific control troubleshooting section.</li> <li><b>Digital control is programmed for Cool or Heat only, or mechanical-control thermostat is rotated too far toward either Cooler or Warmer setting.</b> See digital control manual for reprogramming or see mechanical control operation section in this manual.</li> <li><b>Chilled-water loop is inadequately cooled or heated, chiller system is not in the proper mode of operation, or Electric Heater is disabled.</b> If the air handler system is equipped with water-temperature sensors, check the water temperature at the digital control by pressing the Up and Power buttons simultaneously while in On mode. If the water temperature is not at least 15°F warmer (for heat mode) or cooler (for cool mode), the water valve will not open. See "Temperature Differential of Air &amp; Water" on page 11 and the P-16 programmable parameter for more information. If the air handler system is equipped with an electric heater, ensure that programmable parameter P-13 is set to "ELE".</li> </ol>
Low airflow.	<ol style="list-style-type: none"> <li><b>Airflow is blocked.</b> Remove any obstructions in return-air stream. Clean return-air filter and grille. Check for crushed or restricted ducting; ducting must be as straight, smooth and taut as possible.</li> <li><b>Fan speed is set to Manual Low.</b> If the fan speed is set to Manual Low, press and release the Fan button until the desired fan speed and airflow are reached. If automatic fan-speed control is desired, press and release the Fan button until the indicator light next to the word AUTO is lit.</li> </ol>
System runs continuously.	<ol style="list-style-type: none"> <li><b>Set point temperature is improperly set: too low for cooling or too high for heating.</b> Raise or lower set point.</li> <li><b>Porthole or hatches open.</b> Close all port holes and hatches.</li> <li><b>Improper air sensor location.</b> Check your specific control troubleshooting section.</li> </ol>

## DIGITAL-CONTROLS TROUBLESHOOTING

See also "General Troubleshooting" on page 12.

**Table 4: Digital-Controls Troubleshooting**

PROBLEM	POSSIBLE REASON/SOLUTION
Digital display panel is not lit.	<b>The 8-pin display-cable plugs are not making contact (unplugged, dirty, bent, or broken pins).</b> With POWER OFF at the circuit breaker, remove connector and inspect. If damaged, replace connector or entire display cable.
Fan is not running or runs continuously.	<b>Digital control is set for either fan cycling with cooling/heating demand or continuous fan operation.</b> Press and hold the Fan button for five seconds to change the fan operation to cycled ("CYC") or continuous ("con"). Note: When configured for electric heat, after a heat cycle ends the fan will stay on for 4 minutes even if the fan is set to cycled operation.
Fan is not running but a cooling/heating demand exists.	<b>Failed triac on circuit board.</b> Send for repair or call local service technician.
Fan runs continuously although it is set to cycle with cooling/heating demand.	<b>Failed triac on circuit board.</b> Send for repair or call local service technician.
No cooling or heating.	<ol style="list-style-type: none"> <li><b>Digital control programmed for heat or cool only.</b> Press Mode button to achieve desired mode.</li> <li><b>Chilled-water loop is inadequately cooled or heated, chiller system is not in the proper mode of operation, or Electric Heater is disabled.</b> If the air handler system is equipped with water-temperature sensors, check the water temperature at the digital control by pressing the Up and Power buttons simultaneously while in On mode. If the water temperature is not at least 15°F warmer (for heat mode) or cooler (for cool mode), the water valve will not open. See "Temperature Differential of Air &amp; Water" on page 11 and the P-19 programmable parameter for more information. If the air handler system is equipped with an electric heater, ensure that programmable parameter P-15 is set to "ELE".</li> </ol>
System runs continuously.	<b>Improper air sensor location.</b> Verify display head location with criteria found in the control manual. Install alternate air sensor if necessary.
"ASF" is displayed. (Air Sensor Failure)	<ol style="list-style-type: none"> <li><b>Indicates failed face plate air sensor, alternate air sensor or display cable.</b> Unplug alternate air sensor if installed or plug in alternate air sensor if not installed. Try another display cable.</li> <li><b>Damaged jack/socket in display head or on circuit board.</b> Visually check to see that pins inside socket are not bent or corroded. Repair or replace display or circuit board if needed.</li> </ol>
"FIL" is flashing (Filter Reminder)	<b>Filter needs cleaning or replacement.</b> Clean or replace filter, and reset P-19 to "00".

## MAINTENANCE

### RETURN-AIR FILTER

Check the return-air filter about once a month and clean as necessary. To clean the filter, remove it from the unit, rinse with water, air dry and reinstall.

# SPECIFICATIONS

## OPERATIONAL

Set Point Operating Range . . . . .	65°F to 85°F (18.3°C to 29.4°C)
Ambient Temperature Operating Range Displayed . . . . .	5°F to 150°F (-15°C to 65.6°C)
Sensor Accuracy . . . . .	± 2°F @ 77°F (±1.1°C @ 25°C)
Low Voltage Processor Reset . . . . .	50 VAC
Line Voltage . . . . .	115 Through 240 VAC
Frequency . . . . .	50 or 60 Hz
Fan Output . . . . .	6 Amps @ 115 VAC
Fan Output . . . . .	6 Amps @ 230 VAC
Valve Output . . . . .	1/4 Amp @ 115/230 VAC
For circuit boards <b>revision F and newer:</b>	
Heater Output (using compressor relay) . . . . .	30 Amps @ 115 VAC
Heater Output (using compressor relay) . . . . .	20 Amps @ 230 V
For circuit boards <b>revision E and older:</b>	
Heater Output (using heater relay) . . . . .	30 Amps @ 115 VAC
Heater Output (using heater relay) . . . . .	20 Amps @ 230 V
Minimum Operating Temperature . . . . .	0°F (-17.8°C)
Maximum Ambient Operating Temperature . . . . .	180°F (82.2°C)
Maximum Rh Conditions . . . . .	99% Non Condensing
Power Consumption . . . . .	Less Than 5 Watts

## DIMENSIONS

Display Panel . . . . .	4.41" (112mm) X 2.96" (76mm)
Panel Cut Out . . . . .	3.31" (85mm) X 2.19" (56mm)
Bezel Size . . . . .	4.85" (124mm) X 3.25" (83mm)

## CABLE LENGTHS

Display Cable . . . . .	15' (4.6m) Standard
Alternate Air Sensor (optional) . . . . .	7' (2.1m) Standard
Outside Air Sensor (optional) . . . . .	15' (4.6m) Standard
Water Sensor . . . . .	7' (2.1m) Standard
All custom cable lengths supplied in standard 5' (1.5m) increments . . . . .	75' (22.9m) Maximum



### NOTE

Maximum length of display and sensor cables is 75 feet (22.9m). The outside air sensor and alternate air sensors are optional items and are not included with the standard control package.

## SYSTEM INPUTS

Ambient or Inside Air Temperature . . . . .	1
Water Inlet Temperature Sensor . . . . .	1
Alternate Inside Air Temperature Sensor (optional) . . . . .	1
Outside Air Temperature Sensor (optional) . . . . .	1

## WARRANTY AGREEMENT

This control may be covered under Dometic's Unit Warranty or Dometic's Part Warranty. Please refer to the specific warranty data sheet for more information.

# DIAGRAMS

## SAMPLE APPLICATION

Figure 3: System Layout Example

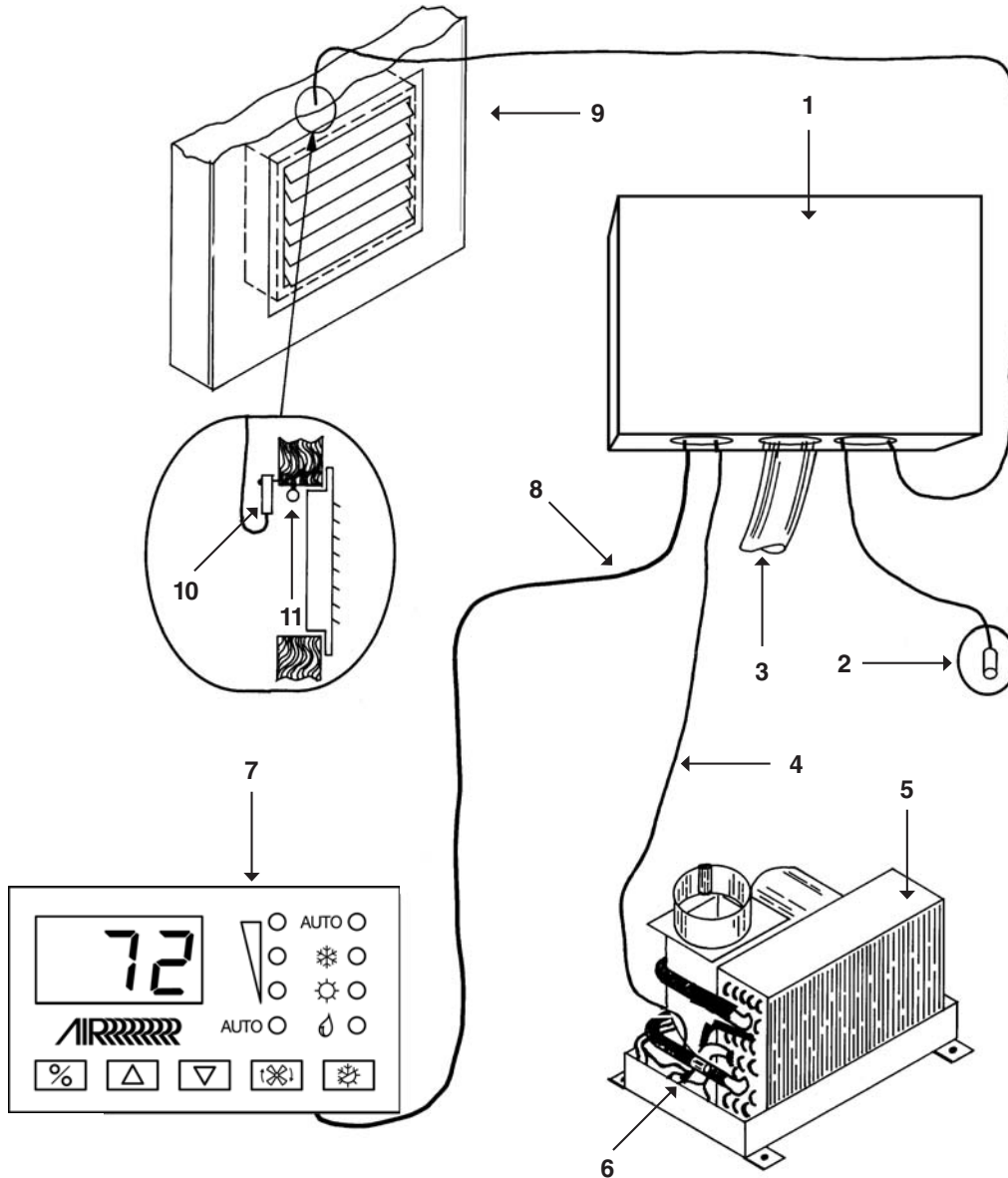

Table 5: System Layout Example - Diagram Legend

1	Electrical Box	6	Water Inlet Sensor
2	Optional Outside Air Sensor	7	Control Display Panel
3	AC Wire Harness	8	8-Conductor Shielded Display Cable
4	6-Conductor Shielded Sensor Cable	9	Return-Air Grille
5	Convector Assembly	10, 11	Optional Remote Air Sensor (your choice of 2 installation locations)

# SAMPLE WIRING DIAGRAM



**IMPORTANT**

This is a sample diagram. Wire colors may vary. See unit's specific diagram located in electrical box or in air conditioning unit's installation manual. Turn power off before opening electrical box.

Figure 4: Sample Digital Control Wiring Diagram

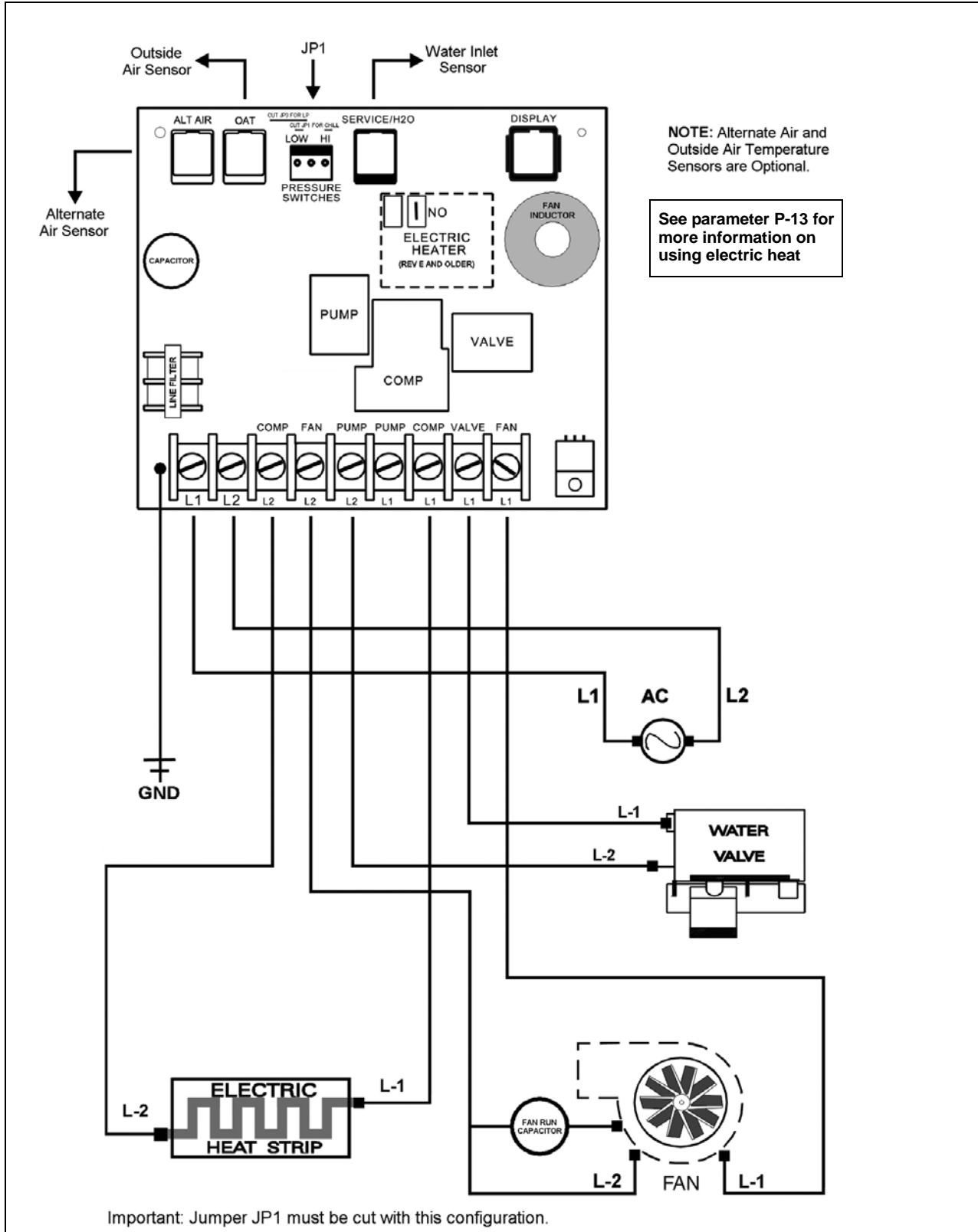

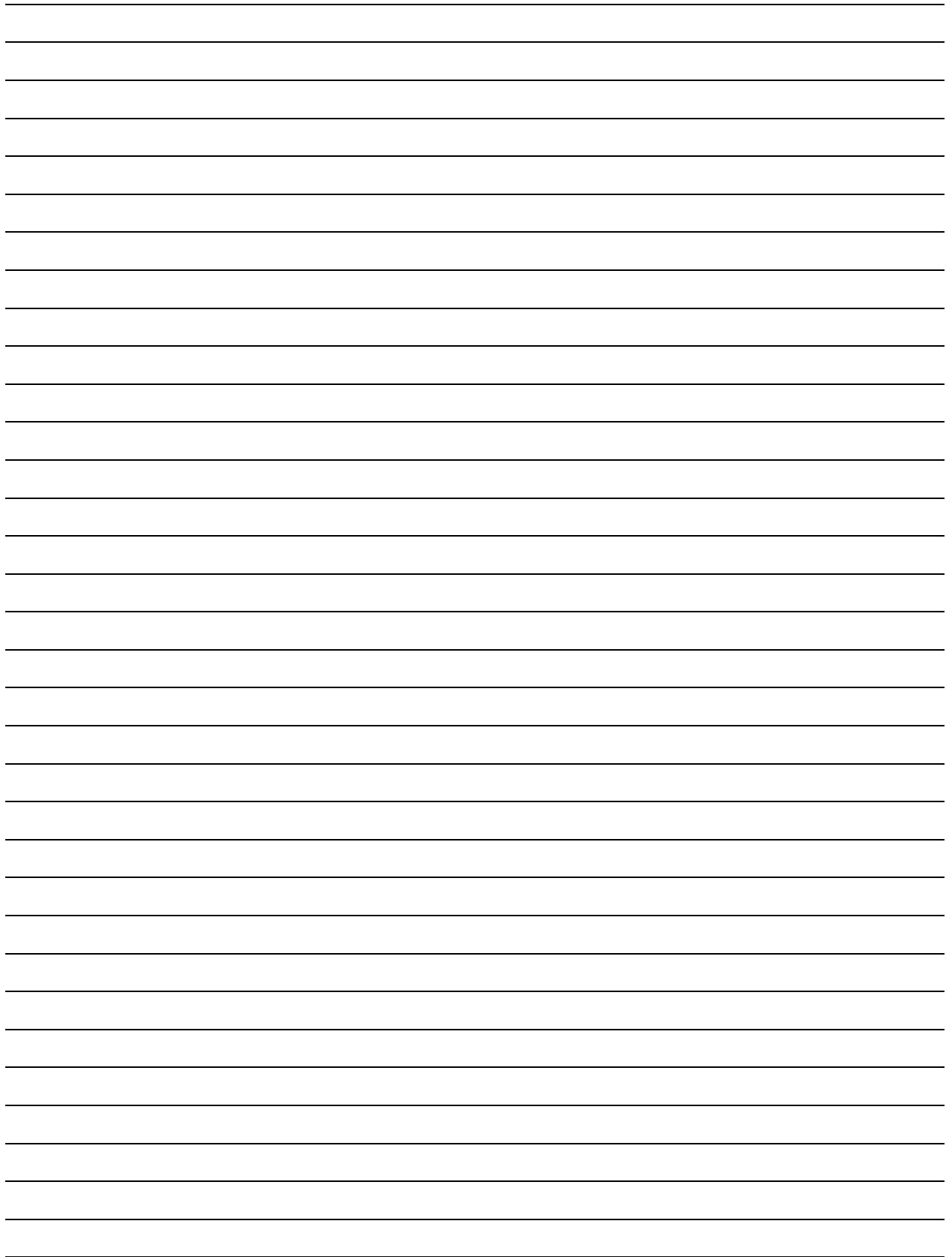

Dometic Marine  
Rev. 20091102  
L-2229 English

[www.dometicusa.com](http://www.dometicusa.com)

