

Model:

# RC 1180 EGP

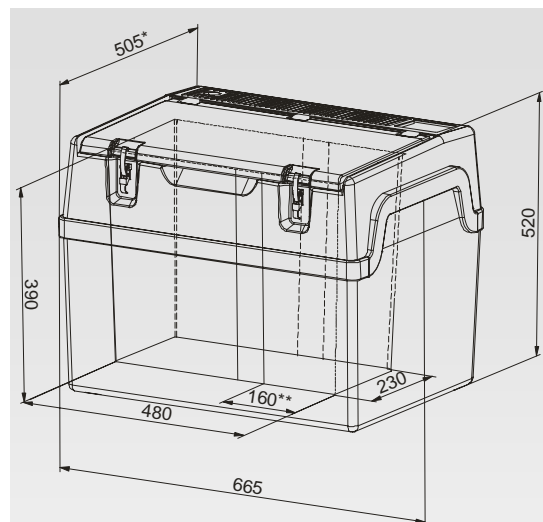

\* Gas connection not included  
(gas connection: max. +20 mm)  
\*\* If freezer's separator wall introduced  
(thickness of wall: 40 mm)

## Technical data

Gross volume	30+16 litres or 50 litres
Net weight	25 kg
Outside dimensions (nominal)	
Height x Width x Depth	520 x 665 x 505 mm
Inside dimensions (nominal)	
Height x Width x Depth	390 x 480 x 230 mm
Packaging dimensions	
- Height x Width x Depth	540 x 705 x 575 mm
- Volume	0,219 m <sup>3</sup>
- Weight	29 kg
Body	Plastic roto-moulded cabinet CFC and HCFC free insulation
Colour	blue body and lid metallic rear cover
Cooling unit	Absorption Virtually silent
Operation	3 ways (12 V / 230 V / gas)
Ice making facility	Ice cubes even at 32°C

Tilt insensitivity	3 degrees
Consumption*	2,10 kWh/24h approx.
- Electricity	240 Ah/24h approx
- 12 V	450 g/24h approx max.
- Gas**	334 g/24h approx min.
(*Average consumption at 25° C ambient according to ISO standards) (**Average consumption for 30 mbar propane)	
Regulation	Thermostat on 230 V Valve 2 positions on gas
Gas operation	Piezo igniter
Electricity operation	120 W max. input 12 V / 230 V
Cable length	230 V : 1,5 mm / 12 V : 2,5 m
Other features	Removable divider to convert 16 litres 2 star freezer and 30 litres refrigerator into a 50 litres fridge. Hermetically sealed lid. Integrated carrying handle Connection direct to the vehicle battery for 12 V (not via the 12 V plug-in)
Factory certifications	ISO 9001 - ISO 14001