

# ATV Air Handlers for Chillers

## Designed With Depth Constraints In Mind



ATV6DC  
model

**The ATV is a chilled-water air handler designed for applications where very little depth is available.** Showcasing a unique vertical layout, this model has the coil low and the blower above.

**Put it in the wall.** Tall and slim, the ATV makes previously unusable areas suitable for blower installation. With a depth of only 9.4 in. (240 mm) it can be hidden in side areas instead of in places above or below, where most air handlers go. Designed for ducted applications, the ATV has a strong yet quiet DC blower with internal motor to reduce depth, resulting in easier installation.

**Heat is just a button-press away.** Typically, each cabin or living space has one or more air handlers, each with an independent climate control to provide passengers with the most comfortable environment on the water. The ATV air handler includes an electric heater to provide supplemental heat in cold climates. The ATV can also provide heat to its cabin even while the chiller is supplying cool air to other areas.

Dometic air handlers have deep drain pans, use corrosion-resistant materials, and are fully insulated to prevent secondary condensation. An optional flow control is highly recommended to help distribute the flow of chilled water more efficiently.

### Key Benefits

- Fits into walls.
- Unique vertical design.
- Minimal depth.
- DC blower provides strong, quiet performance.
- Electric heater included.
- Capacities from 6K - 36K BTU/hr.

# Technical Specifications for ATV Chilled Water Air Handlers

Model	ATV6DC	ATV9DC	ATV12DC	ATV18DC	ATV24DC	ATV36DC
Capacity (BTU/Hr)	6,000	9,000	12,000	18,000	24,000	36,000
Volts/Hz/Ph	208-230/50-60/1	208-230/50-60/1	208-230/50-60/1	208-230/50-60/1	208-230/50-60/1	208-230/50-60/1
Amps (FLA) Cool	1.4	1.4	3.2	3.9	3.9	3.9
Optional Heater KW	1.0	1.0	1.0	1.5	1.5	1.5
Heater Amps	4.3	4.3	4.3	6.5	6.5	6.5
Amps (FLA) Heat	5.7	5.7	7.5	10.4	10.4	10.4
<b>Max. Fuse</b>						
Without Electric Heat	5.0	5.0	5.0	5.0	5.0	5.0
With Electric Heat	10.0	10.0	10.0	15.0	15.0	15.0
Water Flow, GPM (liters/min)	2.25/8.5	2.25/8.5	3.00/11	3.00/11	6.00/23	9.00/34
Air Flow, CFM (m <sup>3</sup> /hr)	200/340 <sup>(2)</sup>	280/476	400/680 <sup>(2)</sup>	600/1020 <sup>(2)</sup>	650/1100	750/1275
External static pressure (in H2O/Pa)	0.75/186	0.75/186	0.75/186	0.75/186	0.75/186	0.50/125
<b>Dimensions (in/mm) <sup>(3)</sup></b>						
Height	22.3/566	22.3/566	24.1/612	27.8/706	34.4/874	34.4/874
Width	20.2/513	20.2/513	20.2/513	21.2/538	29.3/538	29.3/538
H-B	20.5/521	20.5/521	22.1/561	26.0/660	32.5/826	32.5/826
D-P	4.3/109	4.3/109	4.3/109	6.3/160	7.9/201	7.9/201
D-V	6.8/173	6.8/173	6.8/173	7.6/193	9.1/231	9.1/231
D-B	7.4/188	9.4/240	9.4/240	10.3/262	11.5/292	11.5/292
Duct Ring Diameter (in/mm)	5.0/127	6.0/152	6.0/152	7.0/178	8.0/203	8.0/203
Minimum Supply Air Outlet (in <sup>2</sup> /cm <sup>2</sup> )	35/226	49/320	70/450	100/645	140/903	196/1,265
Minimum Return Air Inlet (in <sup>2</sup> /cm <sup>2</sup> )	70/452	98/632	130/839	200/1,290	240/1,548	360/2,323
Drain Connections, Female NPT	1/2"	1/2"	1/2"	1/2"	1/2"	1/2"
Chilled Water Connections, Female NPT	1/2"	1/2"	1/2"	1/2"	1"	1"
Net Weight (lb/kg)	22/10	25/11	31/14	36/16	65/29	65/29
Gross Weight (lb/kg)	32/15	32/15	40/18	46/21	76/34	76/34

**Notes:**

- <sup>(1)</sup> Blower amps will be reduced at lower speed/cfm/static pressure.
- <sup>(2)</sup> To avoid water droplets in the airstream, do not exceed this CFM.
- <sup>(3)</sup> Dimensions are ± 0.3 inches or 8mm.

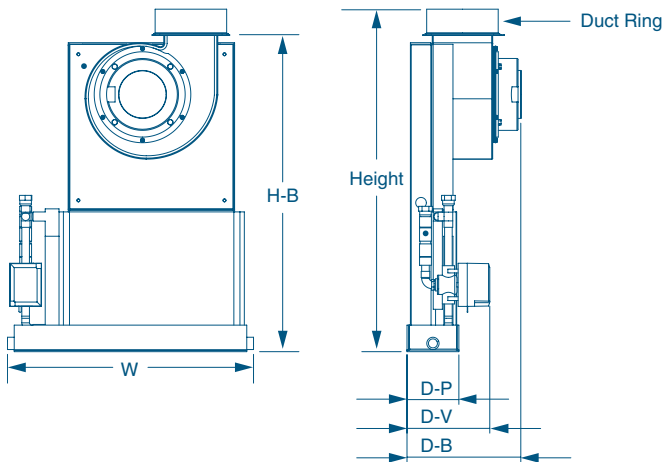

**DOMETIC MARINE DIVISION**

2000 N. Andrews Ave. Ext. I Pompano Beach, FL 33069 USA | 954-973-2477 | Fax 954-979-4414  
[www.DometicUSA.com](http://www.DometicUSA.com) | [MarineSales@DometicUSA.com](mailto:MarineSales@DometicUSA.com)

**24/7 Tech Support for United States & Canada:**

8:00 AM to 5:00 PM Eastern Time: 800-542-2477  
 After hours and weekends: 888-440-4494

**International Sales & Service:**

Europe & the Middle East: Call +44(0)870-330-6101  
 For all other areas visit our website to find your nearest distributor.



Environmentally  
Responsible

Dealer: