

Three  
New Sizes!

# TWC Compact Tempering Unit

## Compact & Enclosed Design



TWC48CK shown

**Cruisair's TWC Compact is a high-performance, cost effective tempering unit.** The reverse cycle TWC cools and heats, and is available in an expanded product range of 24,000 (2-ton) to 72,000 (6-ton) BTU/hr capacities. The three new models include 48,000 (4-ton), 60,000 (5-ton), and 72,000 (6-ton) BTU/hr units. Units can be multiplexed for even larger capacities as required.

Each unit includes a chilled water (CW) flow switch, refrigerant high- and low-refrigerant pressure switches, and inlet and outlet CW temperature sensors. The TWC does not include a chilled water modulating flow control, which means air handlers with or without flow controls can be used.\* The brazed platecoil evaporator and coaxial cupronickel seawater condenser allow for superior cooling and heating performance.

On 2- to 3-ton units, an electrical box mounted on top of the chiller houses the control board as well as starting components, and can be mounted remotely up to 6 ft. (1.8m) away. On 4- to 6-ton units, the electric box is normally contained within the enclosure and does not contribute to height. A remote electric box is available upon request for 4- to 6-ton units.

Two control systems are available. The standard control is our proven Digital Diagnostic Control (DDC) that provides simple, single-stage operation. For multiplexed systems, the Tempered Water Logic Control (TWLC) with LCD screen is available. Depending on the configuration, additional cables, switches, sensors, or a display may be required.

All TWC chillers come with R-410A, the preferred environmentally safe refrigerant used in modern, high-efficiency air conditioning systems.

*\*On larger boats we always recommend using flow-controlled air handlers to ensure proper water distribution. A balancing flow control (BFC) is not needed when using TWC chillers.*

### Key Benefits

- Compact, enclosed design.
- Reverse cycle for cooling and heating.
- High-efficiency rotary or scroll compressors.
- Includes flow switch, high- and low-pressure switches, and inlet and outlet CW temperature sensors.
- Large heat exchangers for superior performance in both cooling and heating.
- Choice of either TWLC or DDC chiller control (included on unit).
- Electrical box can be mounted remotely (2- to 3-ton units).
- All models use R-410A, an environmentally safe refrigerant.
- 24,000 (2-ton) to 72,000 (6-ton) BTU/hr capacities.

# Technical Specifications for TWC Compact Tempering Units

Model	Capacity (BTU/hr) <sup>(1)</sup>	Volts/Hz/Ph <sup>(2)</sup>	FLA Cool	FLA Heat	Dimensions (in/mm) <sup>(3)</sup>					Connections		Weight <sup>(3)</sup> (lb/kg)
					Height 1	Height 2	Width	Depth 1	Depth 2	SW	CW	
TWC24C	24,000	230/60/1	7.5	9.8	22.6/574	18.6/472	13.0/330	18.8/477	19.4/493	5/8" HB	1" FPT/ 1" HB	105/48
TWC24CK		220/50/1	9.5	11.0								
TWC24DC		230/60/3	5.7	7.3								
TWC24EC		460/60/3	2.8	3.6								
TWC24ECK		380/50/3	3.3	4.4								
TWC30C	30,000	230/60/1	9.3	13.5	22.6/574	18.6/472	13.0/330	18.8/477	19.4/493	5/8" HB	1" FPT/ 1" HB	110/50
TWC31CK		220/50/1	10.3	12.0								
TWC32DC		230/60/3	7.2	9.1								
TWC33EC		460/60/3	3.3 <sup>(4)</sup>	4.2 <sup>(4)</sup>								
TWC34ECK		380/50/3	N/A	N/A								
TWC36C	36,000	230/60/1	10.9	15.6	22.6/574	18.6/472	13.0/330	18.8/477	19.4/493	5/8" HB	1" FPT/ 1" HB	110/50
TWC36CK		220/50/1	9.6	12.7								
TWC36DC		230/60/3	8.0	10.2								
TWC36EC		460/60/3	4.1	5.3								
TWC36ECK		380/50/3	4.0	5.6								
TWC48C	48,000	230/60/1	13.0	19.1	23.4/594	N/A <sup>(5)</sup>	13.3/338	18.8/478	23.9/607	1-1/4" FPT	1" FPT	TBD
TWC48CK		220/50/1	14.4	20.7								
TWC48DC		230/60/3	9.1	12.2								
TWC48EC		460/60/3	4.7	6.2								
TWC48ECK		380/50/3	4.9	7.0								
TWC60C	60,000	230/60/1	17.0	24.7	23.4/594	N/A <sup>(5)</sup>	13.3/338	18.8/478	23.9/607	1-1/4" FPT	1-1/4" FPT	TBD
TWC60CK		220/50/1	21.5	30.1								
TWC60DC		230/60/3	10.5	14.4								
TWC60EC		460/60/3	6.2	8.2								
TWC60ECK		380/50/3	6.8	9.1								
TWC72C	72,000	230/60/1	23.3	32.5	23.4/594	N/A <sup>(5)</sup>	13.3/338	18.8/478	23.9/607	1-1/4" FPT	1-1/4" FPT	TBD
TWC72DC		230/60/3	14.2	18.2								
TWC72EC		460/60/3	6.9	9.1								
TWC72ECK		380/50/3	9.0	11.7								

**NOTES:**

- <sup>(1)</sup> Nominal capacity shown, as per ABYC guidelines of the compressor manufacturer's ratings.
- <sup>(2)</sup> Nominal compressor voltage shown. Refer to chart at right for operational voltage ranges.
- <sup>(3)</sup> All dimensions are ± 1/2" (13mm). All weights are ± 10%.
- <sup>(4)</sup> Preliminary data.
- <sup>(5)</sup> Electric box is contained within the enclosure on TWC48-72 models.

**Nominal Compressor Voltage Ranges**

- 230/60/1 = 208-240/60/1
- 220/50/1 = 220-240/50/1
- 230/60/3 = 208-230/60/3 and 200-220/50/3
- 380/50/3 = 380-420/50/3
- 460/60/3 = 440-480/60/3 and 380-420/50/3

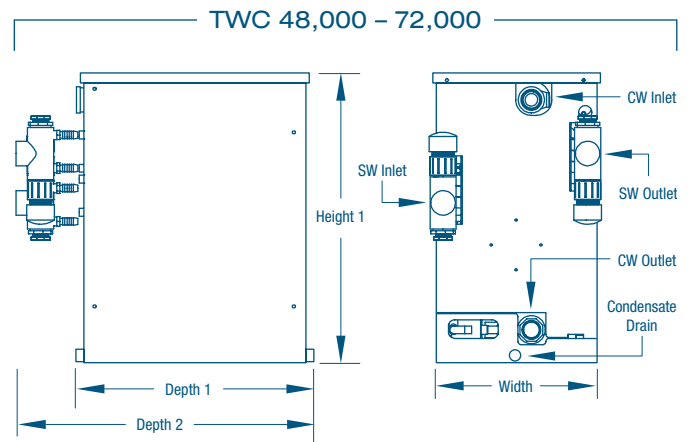
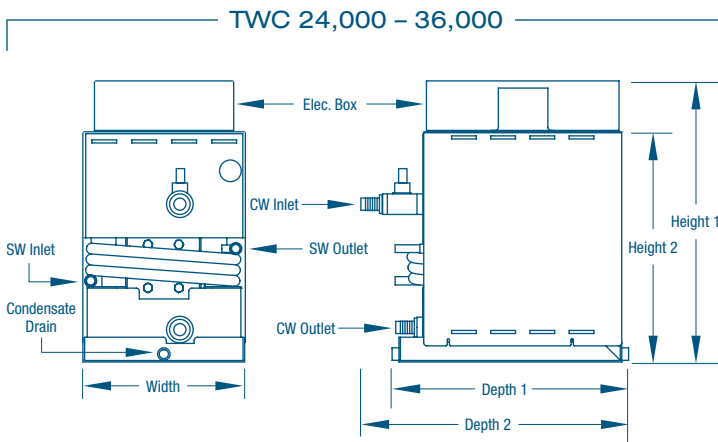

**DOMETIC MARINE DIVISION**

2000 N. Andrews Ave. Ext. I Pompano Beach, FL 33069 USA | 954-973-2477 | Fax 954-979-4414  
 www.DometicUSA.com | MarineSales@DometicUSA.com

**24/7 Tech Support for United States & Canada:**

8:00 AM to 5:00 PM Eastern Time: 800-542-2477  
 After hours and weekends: 888-440-4494

**International Sales & Service:**

Europe & the Middle East: Call +44(0)870-330-6101  
 For all other areas visit our website to find your nearest distributor.



Dealer: