

Grunert Polar Mate Series

Compact Refrigeration Systems

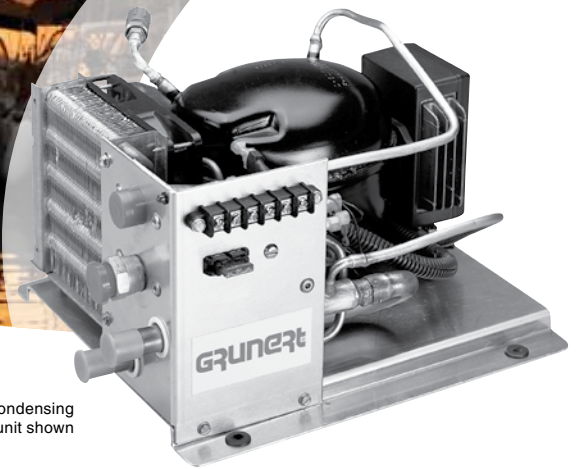

Polar Mate condensing unit shown

The Polar Mate from Grunert provides 12 or 24 VDC, or 115 VAC marine refrigeration in a compact system. Components are specifically designed to fit in restricted areas aboard any vessel. Two models feature air or air/water cooled condensers for maximum versatility. Air cooled units are used when thru-hull fittings are not desired or when the vessel is hauled. Air/water-cooled units also offer water cooling for increased efficiencies and redundant flexibility. Evaporator assemblies are available in both small and large capacities with custom configurations upon request.

The Polar Mate is ideal for small boxes or day sailing applications. For design assistance, contact your local Dealer or the Customer Support Team at Dometic Environmental Corporation.

Polar Mate condensing units can be installed in any convenient location and are practically unaffected by vibration or moisture. All units meet or exceed applicable ABYC and U.S. Coast Guard regulations, CE Directives, and general Air Conditioning and Refrigeration Industry (ARI) standards.



Polar Mate vertical evaporator shown

Key Benefits

- Each unit is equipped with LeakView, an ultraviolet dye system which enables small leaks to be located visually with a UV light.
- Danfoss compressors.
- Smaller, easier-to-use quick connects.
- Receiver for installation and run reliability.
- Cupronickel seawater condensers provide maximum heat transfer and corrosion resistance.
- Unit can be shelf mounted or bulkhead mounted with additional bulkhead mount kit.
- Three evaporator sizes for custom applications.
- 15' (4.6m) refrigeration lineset with "quick connect" fittings.
- Horizontal evaporators are supplied with a door assembly and horizontal ice cube trays.
- Vertical evaporators are supplied with extruded aluminum ice cube trays.
- Charge Guard® protection provides sealed access ports to ensure system integrity during handling and installation.

Technical Specifications for Polar Mate Series

Model	Arctic Air-Cooled PMEA08/12V DC	Antarctic Air/Water-Cooled PMEA08/12V DC	Antarctic-AC Air/Water-Cooled PMEA05	Evap I	Evap II
Voltage ¹	12/24 (DC)	12/24 (DC)	115/60/1 (AC)	N/A	N/A
Refrigerant	R-134A	R-134A	R-134A	R-134A	R-134A
Charge (oz/g)	6.0/170.1	6.5/184.3	8.0/226.8	0.5/14.2	0.5/14.2
Capacity (BTU/hr) ²	433	538	582	N/A	N/A
Capacity (BTU/hr) ³	246	325	336	N/A	N/A
Max Watts ²	65.4	68.5	212.8	N/A	N/A
Max Watts ³	47.6	55.0	196.7	N/A	N/A
Max Amps ²	5.45/2.7	5.71/2.9	1.85	N/A	N/A
Max Amps ³	3.97/2.0	4.58/2.3	1.71	N/A	N/A
Compressor					
Capacity (HP)	1/12	1/12	1/20	N/A	N/A
Power (Watts)	63.0	54.0	37.3	N/A	N/A
RLA					
Compressor	5.3/2.7	4.5/2.3	1.58	N/A	N/A
Fan ⁴	0.2	0.2	0.27	N/A	N/A
Pump	N/A	1.0/0.5	0.92	N/A	N/A
Cut Out Voltage	10.4/22.8	10.4/22.8	N/A	N/A	N/A
Cut In Voltage	11.7/24.2	11.7/24.2	N/A	N/A	N/A
Maximum Fuse ⁵	15.0/7.5	15.0/7.5	7.0	N/A	N/A
Dimensions (in/mm)					
A	10.25/26	10.25/260	11.00/280	10.50/267	15.50/39.
B	11.00/280	11.00/280	12.50/318	6.00/152	6.00/152
C	6.75/171	6.75/171	7.50/190	11.00/279	11.00/279
Weight (lbs/kg)					
Net	14.8/6.7	15.6/7.1	22.0/10.0	6.0/2.7	7.0/3.2
Ship	24.8/11.3	25.6/11.6	25.0/11.3	9.0/4.1	10.0/4.5

Notes:

- ¹ Voltage range is: 12V=10.4-17.0 AND 24V=22.8-31.5. Does not apply to 115VAC model.
- ² Air cooled capacities at 20°F (-6.7°C) evaporator temperature and 120°F (48.9°C) condensing temperature. Water cooled capacities at 20°F (-6.7°C) evaporator temperature 100°F (37.8°C) condensing temperature.
- ³ Air cooled capacities at 0°F (-17.8°C) evaporator temperature, 120°F (48.9°C) condensing temperature. Water cooled capacities at 0°F (-17.8°C) evaporator temperature, 100°F (37.8°C) condensing temperature.
- ⁴ Power to the fan is regulated to 12V regardless of 12V or 24V power input, except for 115VAC model.
- ⁵ For wire size, ampacity, etc., refer to ABYC Standards, Section E8 & E9.

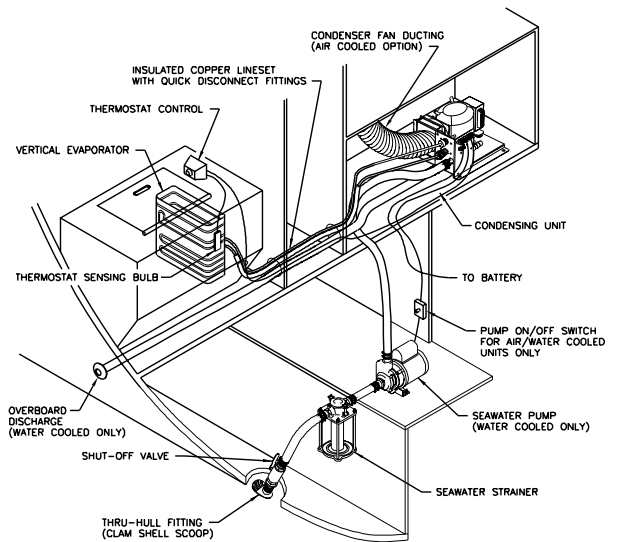
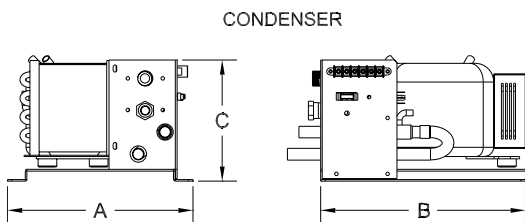

Dealer:

DOMETIC MARINE

2000 N. Andrews Ave. Ext. I Pompano Beach, FL 33069 USA | 954-973-2477 | Fax 954-979-4414
www.DometicUSA.com | MarineSales@DometicUSA.com

United States & Canada Tech Support

8:00 AM to 5:00 PM Eastern Time: 800-542-2477
After hours and weekends: 888-440-4494

International Sales & Service:

Europe & the Middle East: Call +44(0)870-330-6101
For all other areas visit our website to find your nearest distributor.

