

Full-Size Built-In Freezer

With Easy-to-Clean Plastic Interior



■ Frozen treats, anytime.

RPF-50SS shown
without mounting frame.



Equipped with a powerful Danfoss compressor, the RPF-50SS offers 1.6 cubic feet of deep-freezing space. Frozen food is practical and convenient, both at home and on-the-move. But if the freezer compartment in your onboard fridge is too small to accommodate all you want to take on your journey, check out this full-size freezer offered by Dometic. The RPF-50SS can be used as a stand-alone freezer or paired with the same size refrigerator to create a cool side-by-side combination.

During rough sea conditions, the door remains securely closed—at top and bottom—as a result of the patented double-lock door mechanism. When not in use, choose the mechanism's vent position, which holds the door open slightly for easy defrosting and mildew prevention. The attractive, unobtrusive, full width handle provides comfortable use. Enjoy optimal ease of movement with a door you can set to open left or right to accommodate any galley configuration.

Key Benefits

- 12/24 volts DC.
- Optional factory-installed adapter for AC operation.
- Danfoss BD35F compressor provides extremely quiet operation.
- Brushed stainless-steel finish.
- Condensation drain.
- Reversible door opening.
- Interior light.
- Choice of standard mount or flush mount flange.

Specification Details for RPF-50SS

Model	RPF-0050SS
Gross Capacity	1.6 cubic feet
Voltage	12/24V DC
Average Power Consumption	40 watts / 3.3 amps
Insulation	CFC-free polyurethane
Compressor	Danfoss BD35F
Refrigerant	Environmentally-safe R134a
Material	Stainless-steel fittings, plastic interior, door frame in plastic body with coated metal frame
Color	Stainless-steel finish face panel, black door surround, black flange
Cut-Out Dimensions	17.5" W x 20.5" H x 21.12" D 444mm x 520mm x 536mm
Net Weight	55 lbs / 25 kg
Interior Light	Yes
Reversible Door Opening	Yes, left or right
AC Adapter Option	MPS-35
Flange Options: Standard Mount, Black Flush Mount, Black	EST-0200 EFM-0200



■ Condensation drain.



■ Easy to clean plastic interior.

RPF-50SS Dimensions

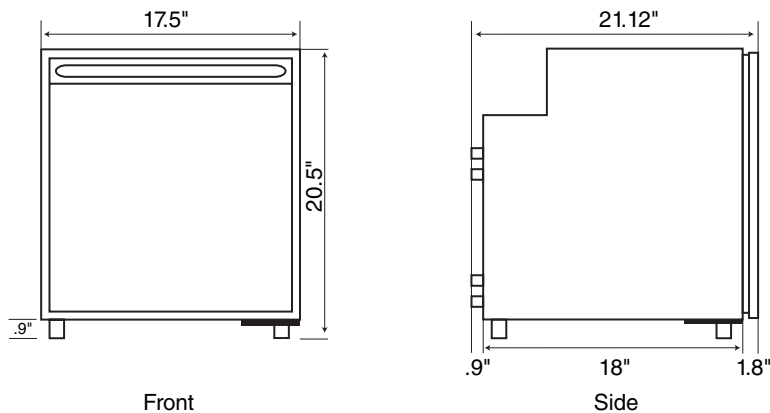

DOMETIC ENVIRONMENTAL CORPORATION

2000 N. Andrews Ave. Ext. | Pompano Beach, FL 33069 USA | 954-973-2477 | Fax 954-979-4414
P.O. Box 15299 | Richmond, VA 23227 USA | 804-746-1313 | Fax 804-746-7248
www.DometicEnviro.com | sales@DometicEnviro.com

United States & Canada Service Only:

8:00 AM to 5:00 PM Eastern Time | Marine Air AC Products: 954-973-2477 | Cruisair AC Products: 804-746-1313

24/7 AC SERVICE HOTLINE: 5:00PM to 8:00 AM: 888-440-4494

International Sales & Service:

Europe & the Middle East: Call +44(0)870-330-6101 | For all other areas visit our website to find your nearest distributor.

ID: 2605 Rev. 20080513

Dealer:



Dometic
THE SIGN OF COMFORT