

# AT-MU Air Handlers

## For Use In Fresh Air Make-Up Systems



ATMU 36 and ATMU 24 models shown

**AT-MU air handlers are designed for use in fresh air make-up (FAMU) systems where outside air is drawn in by the air handler, cooled, dehumidified, and reheated to room temperature, and then ducted to various areas in the vessel.**

The unit consists of a water coil, valve, electric heater, and a blower mounted on a condensate pan/chassis with rubber isolation mounting feet.

A specially designed water coil cools and dehumidifies the outside air in one pass, and is coated, along with the blower and sheet metal, to prevent corrosion. A motorized 3-way bypass valve controls the flow of circulated water through the coil. The high static pressure blower has a high-efficiency internal motor, and can be rotated as required for installation. An electric heater, with redundant over-temperature protections, is included to reheat the cooled air up to a comfortable temperature.

The sloped "Positive-Flow" condensate pan reduces standing water, and is lined with anti-fungal, anti-slosh foam. An optional modulating loop-water flow control regulates the water through the unit to ensure proper water distribution to all air handlers.

Cruisair AT-MU units are available with an integrated "Pulse Heat" control, either in 208VAC or 230VAC, or they can be ordered without a control, and a separate SMX control (with the humidistat option) can be used.

### Key Benefits

- Compact design.
- Corrosion resistant coating on evaporator coil, blower, and sheet metal sloped "Positive-Flow" drain pan with anti-slosh, anti-fungal foam.
- Vibration isolation mounting feet.
- Rotatable, high-efficiency internal-motor blower.
- Integrated 3-way bypass valve with easy-change power head.
- Electric heat with two-stage electric heat overload.
- Heater assembly accessible from top or side.
- Large coil shroud volume for optimum performance.
- Washable air filter.
- Brass hose barbs included for loop water connections.
- Remote air bleeder on 6ft (1.8m) of flexible tubing with ball valve.
- Water pressure test ports for troubleshooting.
- Modulating flow control ensures proper water distribution.
- Hose adapter included for round flex duct connection.
- ISTA Level IIIA certified packaging.

### Options

- Terminal strip style junction box for use with SMX instead of SCR-based controls. Precise voltage (i.e., 208 or 230) need not be specified with this option.

# Technical Specifications for AT-MU Fresh Air Make-up Air Handlers

Model <sup>(1)</sup>	AT18HVZ-1.5KW-MU	AT24HVZ-2KW-MU	AT36HVZ-4KW-MU
Capacity (BTU/Hr)/(Kcal/Hr)	17,000/4284	27,000/6804	53,000/13,356
Voltage @ 50-60Hz/1Ph <sup>(2)</sup>	230	230	230
Amperage (FLA)	7.4	9.5	19.1
Max. Fuse/Min. Circuit Ampacity	10/8	10/10	20/20
Electric Heaters Size (kW)	1.5	2.0	4.0
GPM/(liters/min.)	4.5/17.0	6.0/22.7	9.0/34.1
CFM/(M3/HR.) NOMINAL	174/296	276/469	550/935
External SP (in. H <sub>2</sub> O/eq. Pa)	0.72/180	0.36/90	0.75/190
Dimensions (in/mm) <sup>(3)</sup>			
Height	15.0/380	16.6/422	19.5/495
Width	20.3/514	22.6/575	26.6/676
Depth	12.3/311	15.3/387	18/457
Supply Air Duct Diameter	5/125	6/150	8/200
Return Air Inlet (sq in/cm)	100/645	140/900	220/1400
Loop Water Connections	1/2" FPT with 5/8" brass HB		1" FPT with 1" brass HB
Drain Pan Connections	1/2" FPT with PVC 5/8" brass HB		
Net Weight (lbs/kg)	34/15.5	41/18.6	63/28.6
Gross Weight (lbs/kg)	38/17.3	55/25.0	69/31.4

**Notes:**

<sup>(1)</sup> Electrical and blower data is based on 50Hz performance.

<sup>(2)</sup> Verify voltage! Units with SCR-based controls are designed for either 208VAC or 230VAC. Add "208" to the end of the model number for 208VAC units.

<sup>(3)</sup> Rotatable feet affect the final dimensions. front feet add 1.5" to the front, or 1.1" to both sides. Rear feet do not add to the width or depth when rotated to the side.

## Interpreting Model Numbers

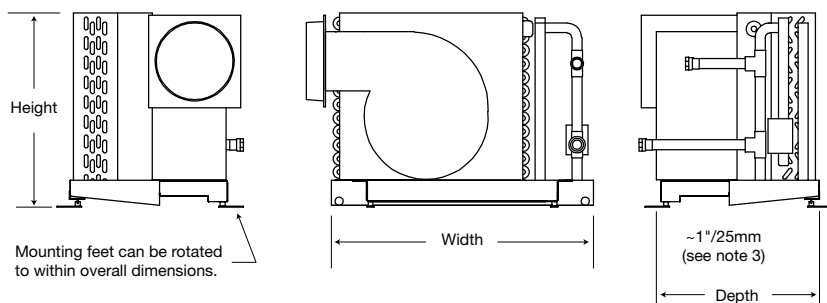
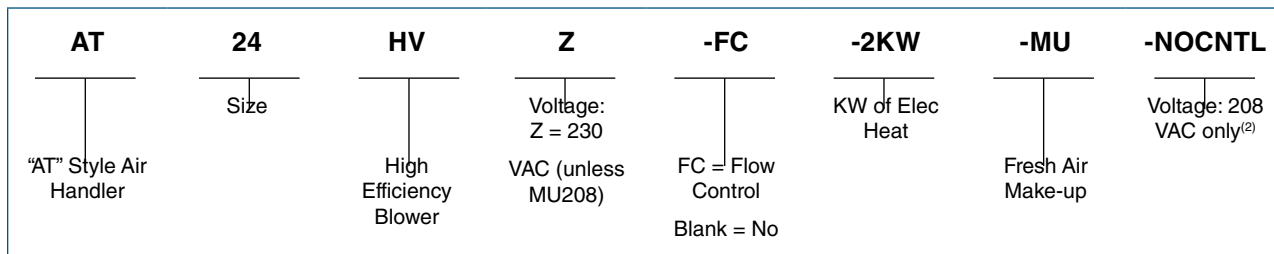

Dealer:



Environmentally Responsible

**DOMETIC CORPORATION, ENVIRONMENTAL DIVISION**

2000 N. Andrews Ave. Ext. I Pompano Beach, FL 33069 USA | 954-973-2477 | Fax 954-979-4414  
 P.O. Box 15299 | Richmond, VA 23227 USA | 804-746-1313 | Fax 804-746-7248  
 www.DometicEnviro.com | sales@DometicEnviro.com

**United States & Canada Service Only:**

8:00 AM to 5:00 PM Eastern Time | Marine Air AC Products: 954-973-2477  
 Cruisair AC Products: 804-746-1313

**24/7 AC SERVICE HOTLINE: 5:00PM to 8:00 AM: 888-440-4494**

**International Sales & Service:**

Europe & the Middle East: Call +44(0)870-330-6101  
 For all other areas visit our website to find your nearest distributor.