

# Built-In Refrigerator & Freezer

## With Stainless-Steel Interior



- Savor the tastes of home.

RSD-115 shown without mounting frame.



**Whether your journeys require reliable refrigeration or deep-freezing capability**, the RSD-115 refrigerator and the RSF-115 freezer meet those needs. Each can be used as a stand-alone installation, or paired to create a cool side-by-side combination.

These attractive built-in units are ideally designed for the rigors of mobile use. A steel frame fitted on all edges keeps the overall body firmly in place. Additional stability is provided by a sturdy steel sheet behind the insulation instead of the typical cardboard fill. The 3.94 cubic-foot refrigerator and the 3.9 cubic-foot freezer are each equipped with a powerful Danfoss compressor.

During rough sea conditions, the door remains securely closed—at top and bottom—as a result of the patented double-lock door mechanism. When not in use, choose the mechanism's vent position, which holds the door open slightly for easy defrosting and mildew prevention. The attractive, unobtrusive, full-width handle provides comfortable opening and closing. Enjoy optimal ease of movement with a door you can set to open left or right to accommodate any galley configuration.

### Key Benefits

- 12/24 volts DC.
- Optional factory-installed adapter for AC operation.
- Danfoss BD35F compressor provides extremely quiet operation.
- Brushed stainless-steel finish.
- Reversible door opening.
- Interior light.
- Choice of standard mount or flush mount flange.

## Specification Details for RSD-115 & RSF-115

Model	RSD-0115E Refrigerator	RSF-0115E Freezer
Gross Capacity	3.94 cubic feet	3.9 cubic feet
Voltage	12/24V DC	12/24V DC
Average Power Consumption	45 watts / 3.3 amps	50 watts / 4.1 amps
Insulation	CFC-free polyurethane	CFC-free polyurethane
Compressor	Danfoss BD35F	Danfoss BD35F
Refrigerant	Environmentally-safe R134a	Environmentally-safe R134a
Material	Stainless-steel fittings, stainless-steel interior, door frame in plastic body with coated metal frame	Stainless-steel fittings, stainless-steel interior, door frame in plastic body with coated metal frame
Color	Stainless-steel face panel, black door surround, black flange	Stainless-steel face panel, black door surround, black flange
Cut-Out Dimensions	20.5"W x 29.12"H x 22"D 520mm x 739mm x 558mm	20.5"W x 29.12"H x 22"D 520mm x 739mm x 558mm
Net Weight	63 lbs / 28.5 kg	63 lbs / 28.5 kg
Interior Light	Yes	Yes
Reversible Door Opening	Yes, left or right	Yes, left or right
AC Adapter Option	MPS-35	MPS-35
Flange Options: Standard Mount, Black Flush Mount, Black	EST-0400 EFM-0400	EST-0400 EFM-0400



- Compressor can be mounted up to five feet away.



- Condensation drain.

## Dimensions for RSD-115 & RSF-115

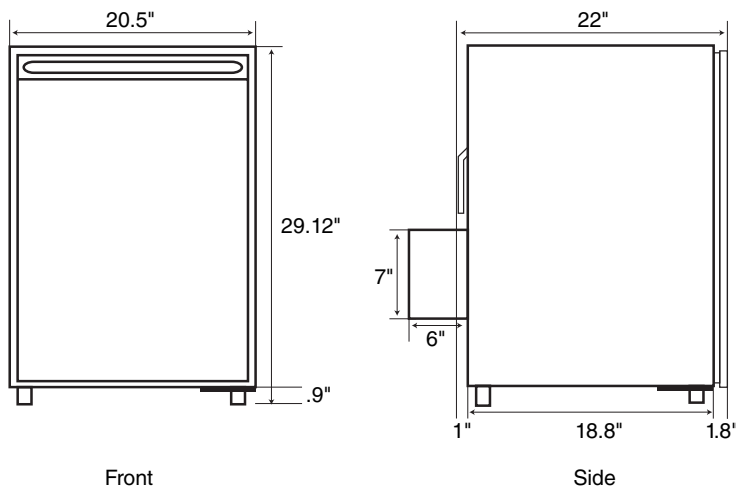

- A powerful side-by-side combo: RSF-115 and RSD-115.

Dealer:

### DOMETIC ENVIRONMENTAL CORPORATION

2000 N. Andrews Ave. Ext. | Pompano Beach, FL 33069 USA | 954-973-2477 | Fax 954-979-4414  
P.O. Box 15299 | Richmond, VA 23227 USA | 804-746-1313 | Fax 804-746-7248  
www.DometicEnviro.com | sales@DometicEnviro.com

### United States & Canada Service Only:

8:00 AM to 5:00 PM Eastern Time | Marine Air AC Products: 954-973-2477 | Cruisair AC Products: 804-746-1313

**24/7 AC SERVICE HOTLINE: 5:00PM to 8:00 AM: 888-440-4494**

### International Sales & Service:

Europe & the Middle East: Call +44(0)870-330-6101 | For all other areas visit our website to find your nearest distributor.

ID: 2603 Rev. 20080513



**Dometic**  
THE SIGN OF COMFORT