

POWER & CONTROL

PRO-TRIM ENGINE TRIM CONTROL

Trim control the way it's meant to be . . . at your fingertips. With Pro-Trim, you can keep both hands on the wheel and concentrate on your driving. Its clean, modern design looks at home in any cockpit and there are no cords to tangle around the steering wheel, a big plus for boats with hydraulic steering!

The Pro-Trim single-switch controls one function (engine trim or jackplate) Pro-Trim Dual controls two functions (trim and jackplate).

SINGLE OR DUAL
FUNCTION

CLEAN & MODERN
DESIGN

NEAT & EASY
INSTALLATION



Mobile living made easy.

 **DOMETIC**

TRIM CONTROL AT YOUR FINGERTIPS.

Engine trim control - single or dual function.

Control any one of these functions... Engine Trim/Tilt, Jackplate, Horn... or any two with Pro-Trim Dual!

Pro-Trim is a "bolt-on" for most SeaStar Solutions steering systems and is attractively packaged, with everything you need.

Also suitable for use with Command 200 rack & pinion steering, and it's the only trim switch recommended for our hydraulic steering systems!

Features

- Momentary-on switch is off in its center "at-rest" position; actuates in up and down directions
- UV-Stabilized ABS switch cover blends with dash
- Strong stainless steel bracket fits most steering systems and adjusts for regular or deep-dish wheels
- Heavy duty marine wiring harness, color-coded to match existing trim and jackplate wiring
- Durable Mylar® decals allow labelling of switch functions
- All mounting hardware and complete, user-friendly instructions included

Order Info

PRO-TRIM CONTROLS	PART NO.
Pro-Trim Single Function	PT1000-1P
Pro-Trim Dual Function	PT2000-1P

Pro-Trim fits any boat using one of the following Dometic steering systems:

- Safe-T mechanical steering
- Rack & Pinion mechanical steering
- NFB No FeedBack steering (all helms)
- SeaStar hydraulic steering
- SeaStar PRO hydraulic steering
- Command 200 Rack & Pinion
- BayStar
- Sport, Sport Plus or Classic Tilt Mechanism

Installation Overview

1. Remove steering wheel

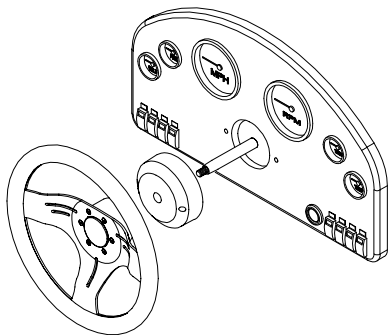

2. Install Pro-Trim

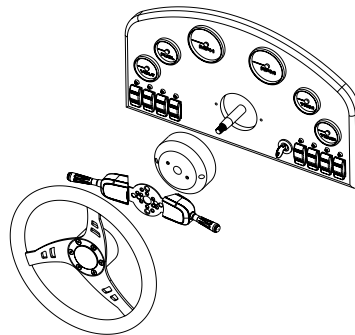

3. Re-install steering wheel

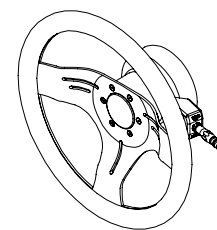

Pro-Trim Single
(PT1000-1P)

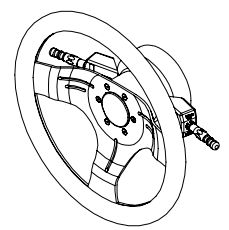

Pro-Trim Dual
(PT2000-1P)

Mechanical Steering Shown